

TM 11-6625-1559-12

DEPARTMENT OF THE ARMY TECHNICAL MANUAL

OPERATOR AND ORGANIZATIONAL
MAINTENANCE MANUAL
INCLUDING REPAIR PARTS AND SPECIAL TOOLS LISTS
GENERATOR, SIGNAL SWEEP

AN/USM-203

(NSN 6625-00-935-0145)

This copy is a reprint which includes current
pages from Changes 1 through 3.

HEADQUARTERS, DEPARTMENT OF THE ARMY

JANUARY 1969

WARNING

Be careful when working on the 115- or 230-volt ac line connections and the +150- and -150-volt dc circuits. Serious injury or DEATH may result from contact with these terminals.

DON'T TAKE CHANCES!

**OPERATOR AND ORGANIZATIONAL MAINTENANCE MANUAL
 GENERATOR, SWEEP SIGNAL
 AN/USM-203
 (NSN 6625-00-935-0145)**

REPORTING OF ERRORS

You can improve this manual by recommending improvements using DA Form 2028-2 located in the back of the manual. Simply tear out the self addressed form, fill it out as shown on the sample, fold it where shown, and drop it in the mail.

If there are no blank DA Form 2028-2 in the back of your manual, use the standard DA Form 2028 (Recommended Changes to Publications and Blank Forms) and forward to the Commander, US Army Communications and Electronics Readiness Command, ATTN: DRSEL-ME-Q Fort Monmouth, NJ 07703.

In either case a reply will be furnished direct to you.

	Paragraph	Page
CHAPTER 1. INTRODUCTION		
Section I. General		
Scope	1-1	1-1
Indexes of publications	1-2	1-1
Forms and records	1-3	1-1
Reporting equipment improvement recommendations (EIRp)	1-3.1	1-1
Administrative storage	1-3.2	1-1
Destruction of Army electronics materiel	1-3.3	1-1
Section II. Description and data		
Purpose and use	1-4	1-1
Technical characteristics	1-5	1-1
Description of equipment	1-6	1-2
Items comprising an operable Generator, Signal Sweep AN/USM-203	1-7	1-2.1
CHAPTER 2. INSTALLATION		
Section I. Service upon receipt of equipment		
Placement of equipment	2-1	2-1
Uncrating and unpacking new equipment	2-2	2-1
Checking unpacked equipment	2-3	2-1
Removal of sweep oscillator shipping screw	2-4	2-1
Seating of tubes, fuses, and crystals	2-5	2-3
Rack mounting	2-6	2-3
Section II. Connections		
Input power connections	2-7	2-5
Oscilloscope connections	2-8	2-6
CHAPTER 3. OPERATING INSTRUCTIONS		
Generator, Signal Sweep SG-593/U operating controls and indicators	3-1	3-1
Types of operation	3-2	3-2
Starting procedure	3-3	3-4
Initial check of equipment	3-4	3-4
Interpretation of markers	3-5	3-5
Measuring bandpass of receiver	3-6	3-7
Measuring bandpass of RF section of receiver	3-7	3-9
Measuring bandpass of IF section of receiver	3-8	3-11
Testing radio frequency amplifiers	3-9	3-11
Testing individual stage in amplifier	3-10	3-13
Testing frequency response and measuring loss of filters and transformers	3-11	3-15
Measuring unloaded bandwidth and Q of cavities or resonant circuits	3-12	3-15
Testing load impedances for proper matching	3-13	3-16
Use of external wobblator drive frequencies	3-14	3-17
Stopping procedure	3-15	3-17

	Paragraph	Page
4. MAINTENANCE INSTRUCTIONS		
Scope of operator's maintenance	4-1	4-1
Preventive maintenance	4-2	4-1
Preventive maintenance checks and services periods	4-3	4-1
Daily preventive maintenance checks and services chart	4-4	4-1
Weekly preventive maintenance checks and services chart	4-5	4-3
Monthly maintenance	4-6	4-4
Monthly preventive maintenance checks and services chart	4-7	4-4
Quarterly maintenance	4-8	4-4
Quarterly preventive maintenance checks and services chart	4-9	4-4
Cleaning	4-10	4-4
Touchup painting instructions	4-11	4-5
Visual inspection	4-12	4-5
General troubleshooting information	4-13	4-5
Troubleshooting chart	4-14	4-5
Tube-testing techniques	4-15	4-6
Fuze replacement	4-16	4-6
5. SHIPMENT, LIMITED STORAGE, AND DEMOLITION TO PREVENT ENEMY USE		
Section I. Shipment and limited storage		
Disassembly of equipment	5-1	5-1
Repacking for shipment or limited storage	5-2	5-1
II. Demolition of materiel to prevent enemy use		
Authority for demolition	5-3	5-1
Methods of destruction	5-4	5-1
APPENDIX A. REFERENCES		A-1
B. BASIC ISSUE ITEMS LIST (BIIL) AND ITEMS TROOP INSTALLED OR AUTHORIZED LIST (ITIAL) (Not Applicable)		
C. MAINTENANCE ALLOCATION		C-1

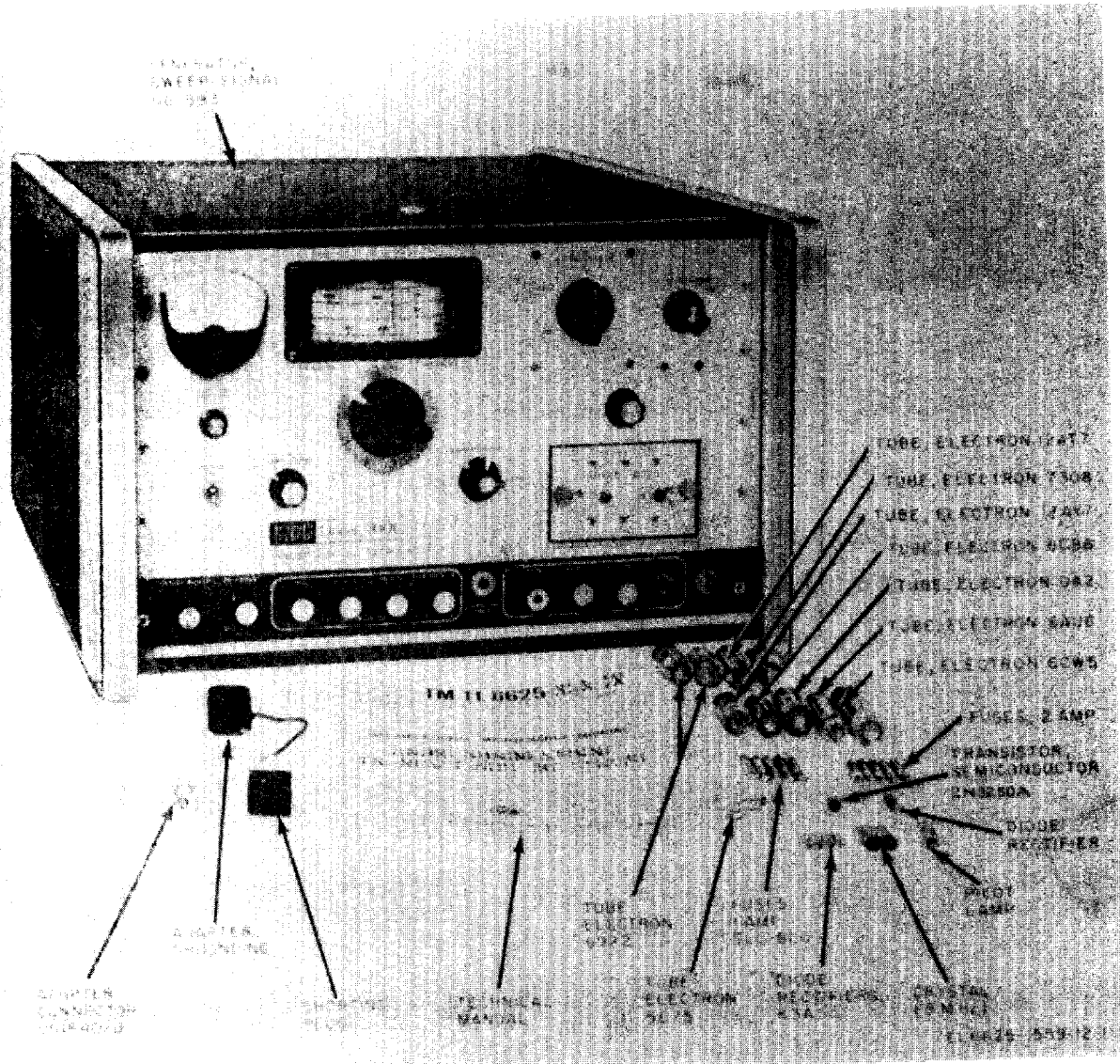

Figure 1-1. Generator, Signal Sweep AN/USM-203.

**CHAPTER 1
INTRODUCTION**

Section I. GENERAL

1-1. Scope

This manual describes Generator, Signal Sweep AN/USM-203. It covers instructions for operation and installation, and for operator and organizational maintenance, cleaning and inspection of the equipment, and replacement of parts available to the operator and organizational repairman.

1-2. Indexes of Publications

a. DA Pam 310-4. Refer to DA Pam 310-4 to determine whether there are new editions, changes, or additional publications pertaining to the equipment.

b. DA Pam 310-7. Refer to DA Pam 310-7 to determine whether there are modification work orders (MWO's) pertaining to the equipment.

1-3. Forms and Records

a. Reports of Maintenance and Unsatisfactory Equipment. Maintenance forms, records, and reports which are to be used by maintenance personnel at all maintenance levels are listed in and prescribed by TM 38-750.

b. Report of Packaging and Handling Deficiencies. Fill out and forward DD Form 6 (Packaging Improvement Report) as prescribed in AR 700-58/NAVSUPINST 4030.29/AFR 71-13/MCO P4030.29A, and DLAR 4145.8.

c. Discrepancy in Shipment Report (DISREP) (SF 361). Fill out and forward Discrepancy in

Shipment Report (DISREP) (SF 361) as prescribed in AR 55-38/NAVSUPINST 4610.33B/AFR 75-18/MCO P4610.19C, and DLAR 4500.15.

1-3.1. Reporting Equipment Improvement Recommendations (EIR)

EIR's will be prepared using Standard Form 368 (Quality Deficiency Report). Instructions for preparing EIR's are provided in TM 38-750 (The Army Maintenance Management System). EIR's should be mailed direct to Commander, US Army Communications and Electronics Materiel Readiness Command, ATTN: DRSEL-ME-MQ, Fort Monmouth, NJ 07703. A reply will be furnished direct to you.

1-3.2. Administrative Storage

There are no special procedures for preparing this equipment for limited storage. Place all ancillary items as shown in figure 1-1 in a bag. Tie or tape the bag to the equipment. Place equipment in an organizational storage room. Protect equipment from dust, humidity, and extreme temperature changes.

1-3.3. Destruction of Army Electronics Materiel

Destruction of Army electronics materiel to prevent enemy use shall be in accordance with TM 750-244-2.

Section II. DESCRIPTION AND DATA

1-4. Purpose and Use

a. Generator, Signal Sweep AN/USM-203 is a portable, wide-band radio frequency (rf) generator with a frequency range of 500 kiloHertz (kHz) to 1,200 megaHertz (MHz), and sweep widths variable from 10 kHz to 400 MHz. The unit produces crystal-controlled, pulse-type frequency marker signals at 1, 10, and 100 MHz and at all multiples of these frequencies within the range of the unit. Also, provisions are made for the insertion of one or two externally generated marker signals. Throughout this manual, Generator, Signal Sweep SG-593/U (the main component of Generator, Signal Sweep AN/USM-203) will be referred to as the sweep generator.

b. The sweep generator can be used in conjunction with an external oscilloscope to measure

frequency response, gain and bandpass of receivers, amplifiers, filters, transformers, cavities, and resonant circuits. It can also be used to measure the sending-end impedance of a loaded transmission line to determine proper matching.

1-5. Technical Characteristics

Frequency range:

- Vhf (wide and narrow)500 kHz to 400 MHz.
- Unf (narrow)350 MHz to 1,200 MHz.
- UNF (wide)275 Mhz to 1,100 MHz

Sweep width:

- Vhf (narrow)10 kHz or less minimum;
1 MHz or more maximum.
- Vhf(wide)500 kHz or less minimum;
400 MHz or more maximum.
- Unf (narrow) 10 kHz or less minimum;
1 MHz or more maximum.

TM 11-6625-1559-12

Uhf (wide)	500 kHz or less minimum; 40% of center frequency or more, maximum.
Output voltage:	
Vhf	0.25volt rms or more into 50-ohm load.
Uhf	0.5volt rms or more into 50- ohm load.
Output voltage variation:	
Vhf	±0.5 db at maximum sweep width
Uhf	±0.5 db to 800 MHz and ±1.5 db from 800 to 1,200 Mhz at maximum sweep width. Output voltage variation less at narrower sweep widths.
Spurious beats and harmonics	20 db or more below funda- mental output.
Impedance	50 ohms, nominal.
Detector	Full-wave peak-to-peak feed through type: vswr less than 1.3:1 up to 900 MHz and less than 1.4:1 up to 1,200 MHz with a termina- tion vswr is 1.05:1 or bet- ter.
Horizontal frequency modulation	Obtained from powerline fre- quency, shaped to sinusoidal form.
Horizontal deflection voltage	20 volts, peak-to-peak.
Markers (internal)	Crystal-controlled harmonic markers at 1, 10, and 100 MHz intervals. Each mark- er group output is individ- ually controlled from the front panel.
Marker input (external)	Requires 20 millivolts or more. Gain of marker ampli- fier is variable from 0 to 100.
Oscilloscope preampli- fier	Gain variable from 2 to 200 (46 db). ac or dc coupling to the oscilloscope input may be selected.
Attenuator	Adjustable from 0 to 50 db in 10-db increments.
Frequency dial	Calibrated in four ranges with an accuracy of ±1 dial

division on Uhf ranges:
Vhf narrow: 0 to 450 mc;
Vhf wide: 0 to 460 mc;
Uhf narrow: 340 to 1,200

Uhf wide: 275 to 1,100
mc.

VOLTS meter Provides output voltage level
measurement accurate
within ±1 db from 0 to 400
MHz. For accuracy above
400 MHz see calibration
curve, figure 1-2.

Blanking Return trace blanking is op-
tional by means of panel
switch. Blanks to 0 voltage.

Power source require-
ments 100 to 130, or 200 to 260
volts ac at 50 or 60 cycles.

Power consumption Approximately 100 watts.

1-6. Description of Equipment

a. Generator, Signal Sweep SG-593/U. The sweep generator is constructed of a welded aluminum frame which holds the RF components, the main chassis, and four removable chassis modules. It is surrounded by a heavy welded steel cabinet with a top cover, which is removable for maintenance. The entire cabinet is removable for rack-mounting of the unit. The operating controls and RF OUTPUT jack are located on the front panel of the unit. The removal model D-50 detector module is also mounted on the front panel. Jacks for connecting auxiliary equipment (oscilloscope, etc) are located at the rear of the unit. The following removable chassis modules are mounted on the main chassis (fig. 1-3):

- (1) Preamplifier and marker amplifier.
- (2) Mixer and VHF-ALC detector.
- (3) Harmonic marker generator.
- (4) ALC amplifier, blanking circuit and meter Amplifier.

b. Adapter-Connector UG-1640/U. The UG-1640/U provides correct impedance match for detector output.

1-7. Items Comprising an Operable Generator, Signal Sweep AN/USM-203

<i>FSN</i>	<i>QTY</i>	<i>Nomenclature, part No., and mfr code</i>	<i>Fig. No.</i>
------------	------------	---	-----------------

NOTE

The part number is followed by the applicable 5-digit Federal supply code for manufacturers (FSCM) identified in SB 708-42 and used to identify manufacturer, distributor, or Government agency, etc.

6625-00-935-0145		Generator, Sweep AN/USM-203: (This item is nonexpendable) which includes:	
5935-00-838-5183	1	Adapter, Grounding: 210, 82879	1-1
5935-00-500-9851	1	Connector, Plug, Electrical UG-1640/U	1-1
6625-00-070-7998	2	Dummy Load, Electrical DA-505/U	1-1
6625-00-935-8109	1	Generator, Sweep SG593/U: (This item is nonexpendable)	1-1

¹As measured at front panel DETECTOR jack.

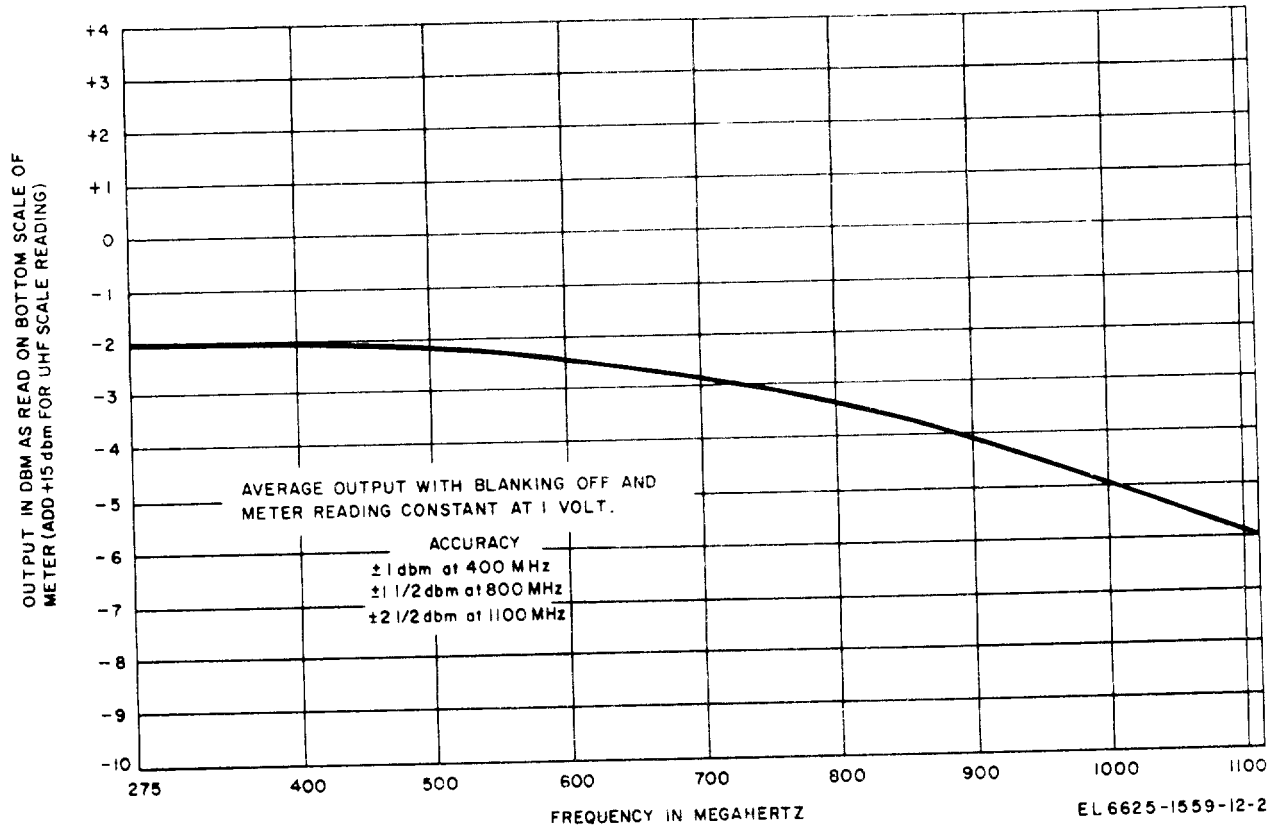

Figure 1-2. VOLTS meter calibration curve.

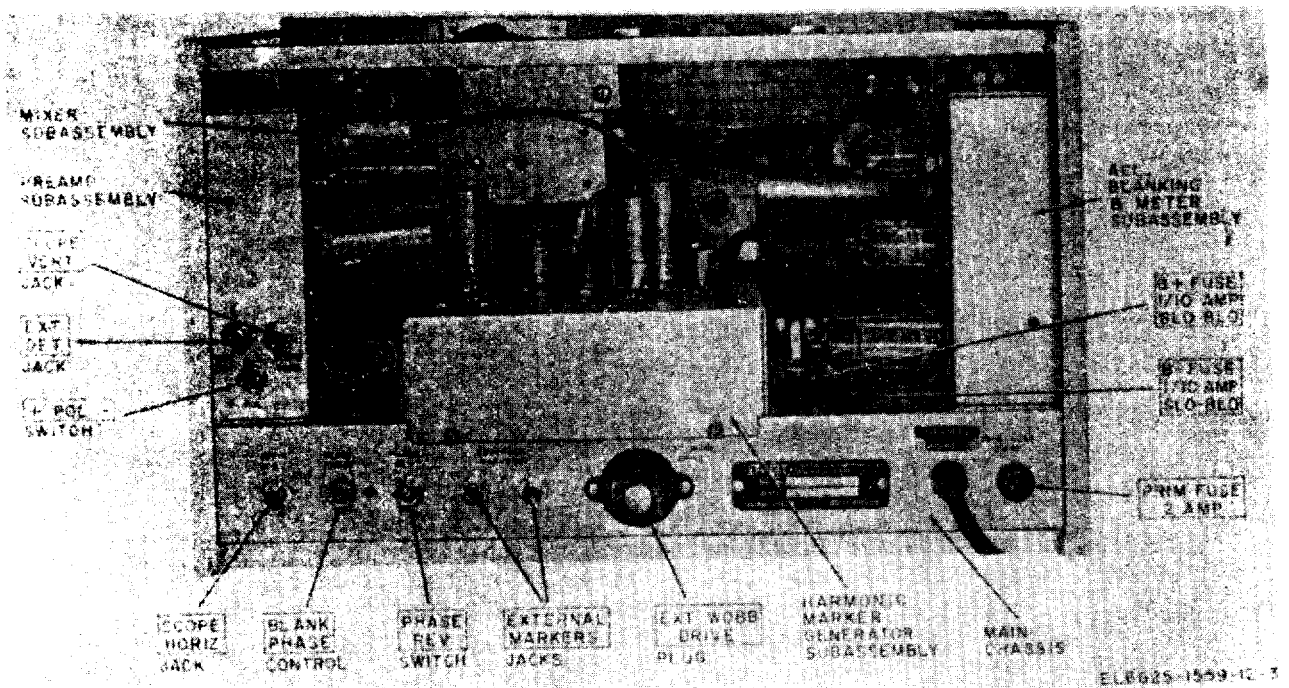

Figure 1-3. Generator, Signal Sweep SG-593/U, rear view.

CHAPTER 2 INSTALLATION

Section I. SERVICE UPON RECEIPT OF EQUIPMENT

2-1. Placement of Equipment

The sweep generator can be rack-mounted or used on a bench. A 115- or 230-volt, 50- or 60-cycle alternating current (ac) outlet should be located close to the sweep generator. Place the sweep generator near the oscilloscope and the equipment to be tested so that its controls and the oscilloscope controls are within easy reach.

2-2. Uncrating and Unpacking New Equipment

Sometimes, the equipment may be shipped in export packing cartons or in domestic packing cartons. When new equipment is received, select a location where the equipment may be unpacked without exposure to the elements. The instructions given in *a* below apply to equipment shipped in export corrugated cartons and the instructions given in *b* below apply to equipment shipped in domestic packing cartons.

a. Step-by-Step Instructions for Unpacking Export Shipments (fig. 2-1).

(1) Place the shipping carton as near the operating position as possible.

(2) Cut through the upper three edges of the carton. The uncut edge will act as a hinge.

(3) Open the carton and remove the outer corrugated carton and the water-vapor-proof barrier around the carton.

(4) Cut the barrier as close to the seal as possible and carefully remove the barrier material.

(5) Open the carton as described in (2) above.

(6) Remove the inner corrugated carton and open the carton as described in (2) above.

(7) Remove the corrugated fillers from the carton.

(8) Remove the equipment from the carton and place it on a workbench or near its final location.

b. Unpacking Domestic Packing Carton. The instructions given in *a* above apply to the unpacking of domestic shipments. If heavy wrapping paper has been used around the corrugated carton, carefully remove it and follow the procedure given in *a*(5) through (8) above.

2-3. Checking Unpacked Equipment

a. Inspect the equipment for damage incurred during shipment. If the equipment has been damaged, report the damage on DD Form 6 (para 1-3).

b. See that the equipment is complete as listed on the packing slip. Report all discrepancies in accordance with TM 38-750. Shortage of a minor assembly or part that does not affect proper functioning of the equipment should not prevent use of the equipment.

c. If the equipment has been used or reconditioned, see whether it has been changed by a modification work order (MWO). If the equipment has been modified, the MWO number will appear on the front panel near the nomenclature plate. If modified, see that any changes resulting from the modification have been entered in the equipment manual.

NOTE

Current MWO's applicable to the equipment are listed in DA Pam 310-7.

2-4. Removal of Sweep Oscillator Shipping

The sweep oscillator is held rigid during shipment by a shipping screw which fastens the oscillator housing to a bracket on the right side of the sweep generator frame (fig. 2-2). After unpacking the equipment, remove the shipping screw and thread it into the adjacent hole provided for storage. To reach the shipping screw, loosen the screw fastener that secures the top

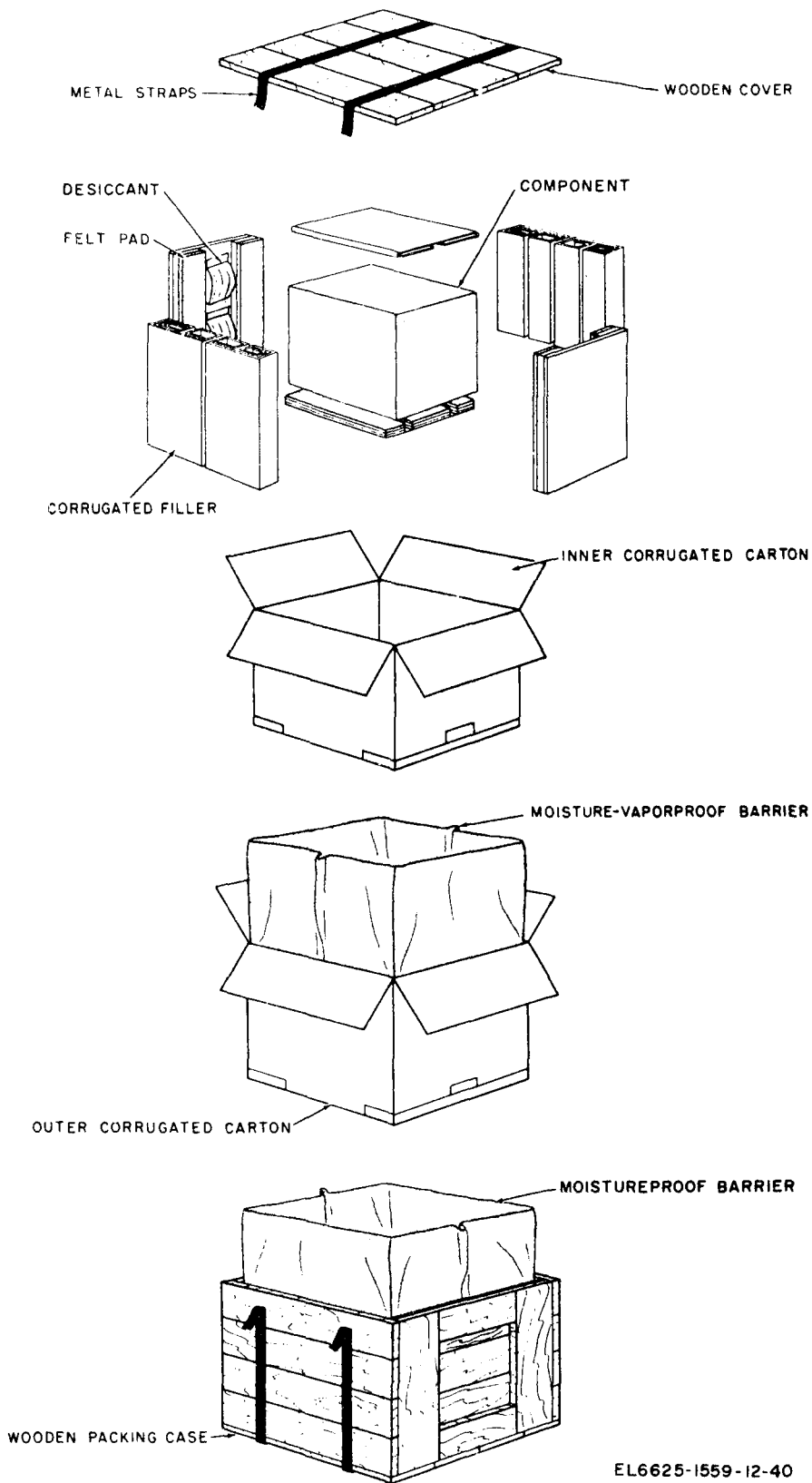

EL6625-1559-12-40

Figure 2-1. AN/USM-203 packaging.

cover of the cabinet and open the cover. After removing the shipping screw, check to see that the sweep oscillator floats free on its rubber mountings.

2-5. Seating of Tubes, Fuses, and Crystals

The sweep generator is shipped with tubes, fuses, and crystals installed.

a. Check for breakage and proper seating of tubes. To reach tubes, loosen the screw fastener that secures the top cover of the cabinet and open the cover (fig. 2-2).

b. Check to see that the fuses are installed in the fuseholder. The following chart shows the locations and ratings of the fuses:

Fuse (fig.1-3)		
Ref symbol	Rating (amp)	Circuit
F 1	2	Ac input
F 2	0.1	Plate supply (+)
F 8	0.4	Plate supply (-)

c. Check to see that the 5-MHz crystal is properly installed in its holder in the harmonic marker generator module (fig. 2-2).

2-6. Rack Mounting

Mount the sweep generator in a standard 19-inch rack as follows:

Caution: Make sure the rear of the sweep generator is well supported in the rack.

a. Remove the three screws from the angle bracket at each side of the front panel (total of six screws), and remove the angle brackets.

b. Remove the two screws at the top and two screws at the bottom, which secure the handle at each side of the front panel to the cabinet (total of eight screws).

c. Remove the three screws located under the angle brackets (a above) on each side of the front panel (total of six screws),

d. Slide the unit from the cabinet and install it in the rack.

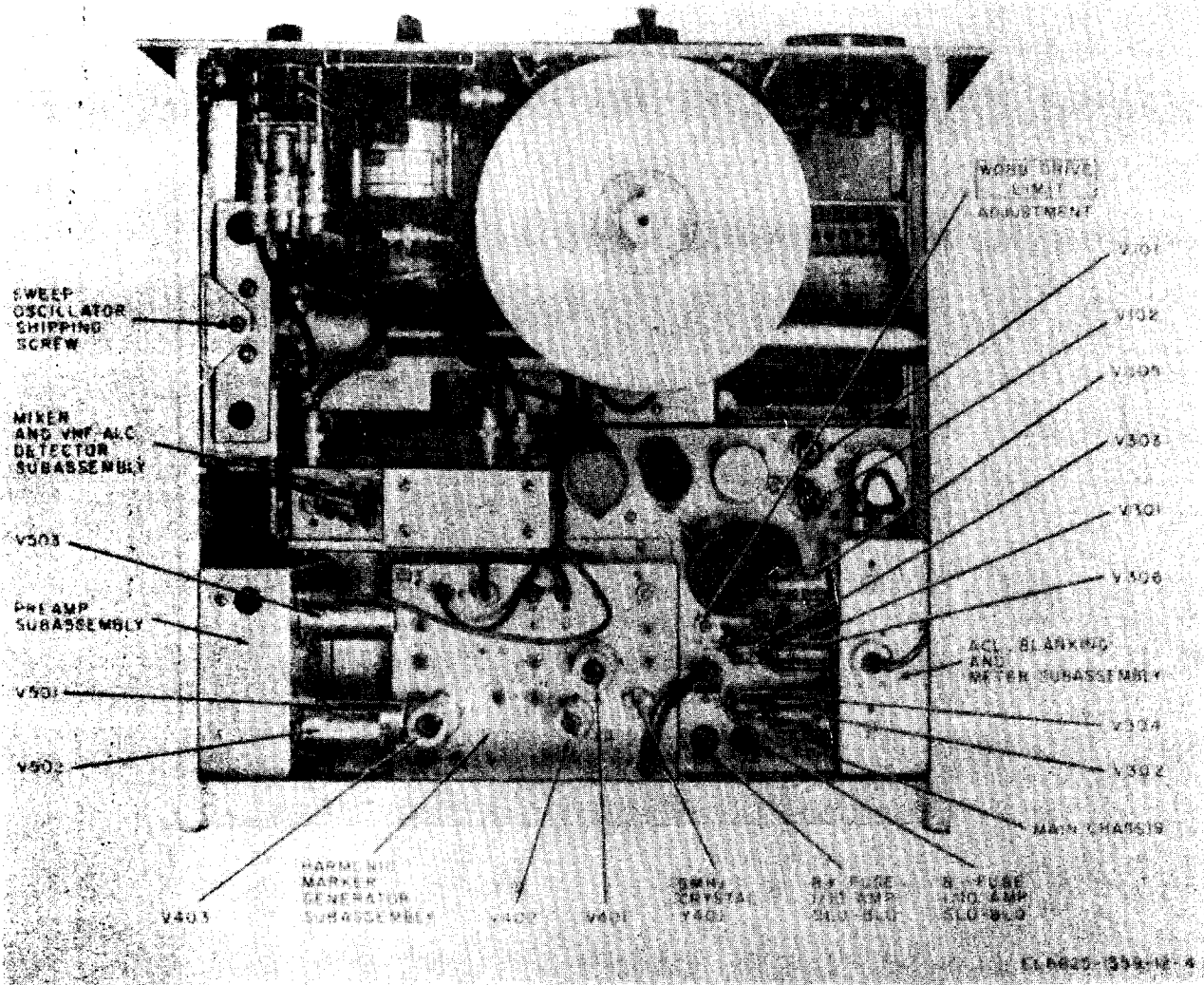

Figure 2-2. Sweep Signal Generator AN/USM-203, top view, cabinet removed.

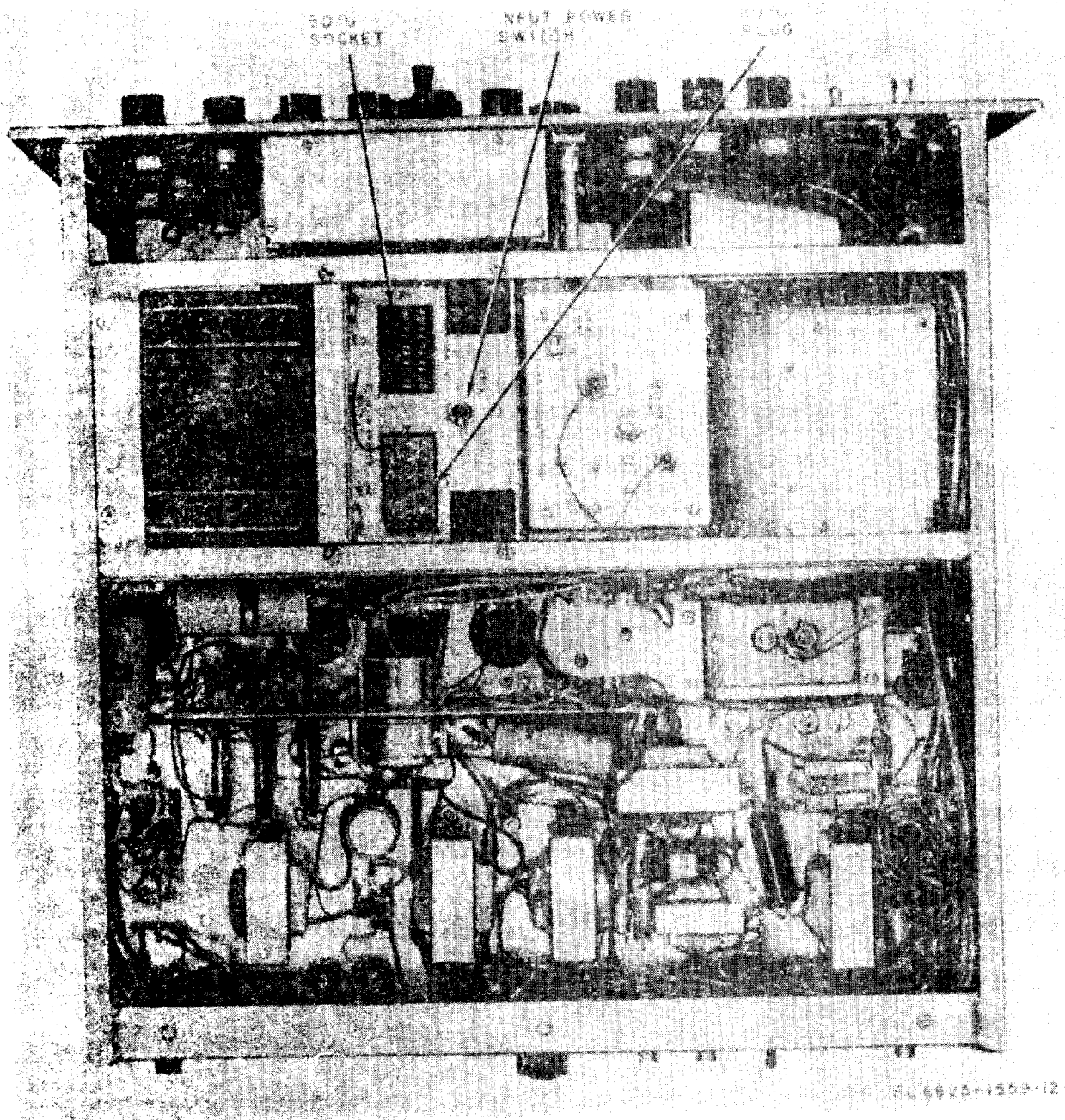

Figure 2-3. Sweep Signal Generator AN/USM-203, bottom view, cabinet removed.

Section II. CONNECTIONS

2-7. Input Power Connections

The sweep generator is designed to operate from input power of either 115 or 230 volts ac, at a frequency of either 50 or 60 cycles. An input power switch, located under the main chassis (fig. 2-3), can be set to either the 115V or

230V position to provide operation at the available input voltage. A frequency changing plug, also located under the main chassis, can be mated to one of two sockets (labeled 60 \sim and 50 \sim) to provide operation at the available frequency. The sweep generator is shipped with the input power switch set to the 115V position,

and the frequency changing plug mated to the socket marked 60 \sim . For operation at 230 volts, set the input power switch to 230V. If the frequency of the input power is 50 cycles, connect the plug to the socket marked 50 \sim .

2-8. Oscilloscope Connections

The sweep generator must be used in conjunction with an external oscilloscope to provide a visual presentation of the response curves of the

equipment to be tested. Place the oscilloscope at the side of the sweep generator and connect the two units as follows:

a. Connect the vertical amplifier input of the oscilloscope to the SCOPE VERT jack on the preamplifier chassis at the rear of the sweep generator (fig. 1-3).

b. Connect the horizontal amplifier input of the oscilloscope to the SCOPE HORIZ jack on the rear panel of the main chassis.

CHAPTER 3

OPERATING INSTRUCTIONS

Note. This chapter covers only items used by the operator; items used by higher maintenance category personnel are covered in instructions for the appropriate maintenance category.

3-1. Generator, Signal Sweep SG593/U Operating Controls and Indicators (fig. 3-1)

Control or indicator	Function										
VOLTS meter -----	Three-scale voltmeter which provides the following readings:										
	<table border="0" style="width: 100%;"> <thead> <tr> <th style="text-align: left;">Scale</th> <th style="text-align: left;">Reading</th> </tr> </thead> <tbody> <tr> <td>UHF -----</td> <td>Indicates output voltage for uhf ranges. Calibrated from 0.5 to 2 volts in 0.5-Volt steps.</td> </tr> <tr> <td>VHF -----</td> <td>Indicates output voltage for vhf ranges. Calibrated from 0 to 0.35 volt in 0.1-volt steps.</td> </tr> <tr> <td>DBM -----</td> <td>Calibrated from -10 to +4 dbm in 1-dbm steps. Read directly for vhf. Add 15 dbm for uhf.</td> </tr> </tbody> </table>	Scale	Reading	UHF -----	Indicates output voltage for uhf ranges. Calibrated from 0.5 to 2 volts in 0.5-Volt steps.	VHF -----	Indicates output voltage for vhf ranges. Calibrated from 0 to 0.35 volt in 0.1-volt steps.	DBM -----	Calibrated from -10 to +4 dbm in 1-dbm steps. Read directly for vhf. Add 15 dbm for uhf.		
Scale	Reading										
UHF -----	Indicates output voltage for uhf ranges. Calibrated from 0.5 to 2 volts in 0.5-Volt steps.										
VHF -----	Indicates output voltage for vhf ranges. Calibrated from 0 to 0.35 volt in 0.1-volt steps.										
DBM -----	Calibrated from -10 to +4 dbm in 1-dbm steps. Read directly for vhf. Add 15 dbm for uhf.										
PULL TURN FOR ZERO switch/control -----	<i>In</i> position is normal operating position. <i>Out</i> position permits adjusting electrical zero of VOLTS meter.										
FREQUENCY MEGAHERTZ dial -----	Four-scale dial which indicates the center frequency of the frequency range being swept. The scale in use is indicated by illuminated arrows at each side of the dial. Scales are calibrated as follows:										
	<table border="0" style="width: 100%;"> <thead> <tr> <th style="text-align: left;">Scale</th> <th style="text-align: left;">Range</th> </tr> </thead> <tbody> <tr> <td>Top -----</td> <td>Uhf narrow: 350 to 1,200 MHz in 10-MHz steps.</td> </tr> <tr> <td>Second -----</td> <td>Uhf wide: 275 to 1,100 MHz in 10-MHz steps.</td> </tr> <tr> <td>Third -----</td> <td>Vhf wide: 0 to 460 MHz in 10-MHz steps.</td> </tr> <tr> <td>Bottom -----</td> <td>Vhf narrow: 0 to 450 MHz in 10-MHz steps.</td> </tr> </tbody> </table>	Scale	Range	Top -----	Uhf narrow: 350 to 1,200 MHz in 10-MHz steps.	Second -----	Uhf wide: 275 to 1,100 MHz in 10-MHz steps.	Third -----	Vhf wide: 0 to 460 MHz in 10-MHz steps.	Bottom -----	Vhf narrow: 0 to 450 MHz in 10-MHz steps.
Scale	Range										
Top -----	Uhf narrow: 350 to 1,200 MHz in 10-MHz steps.										
Second -----	Uhf wide: 275 to 1,100 MHz in 10-MHz steps.										
Third -----	Vhf wide: 0 to 460 MHz in 10-MHz steps.										
Bottom -----	Vhf narrow: 0 to 450 MHz in 10-MHz steps.										
FREQUENCY MEGAHERTZ knob -----	Rotates FREQUENCY MEGAHERTZ dial to desired position. Divides 10 MHz steps on dial into 2-MHz increments.										
FINE TUNING control -----	Provides small increment frequency adjustment.										
ATTENUATOR db switch -----	Attenuates sweep generator output in 10-db steps from 0 to 50 db.										
BAND SELECTOR switch -----	VHF position selects vhf range of center frequencies. UHF position selects uhf range of center frequencies.										
RF OUTPUT control -----	Varies sweep generator output amplitude at RF OUTPUT jack.										

Control or indicator	Function
POWER switch -----	Applies and disconnects ac input power to sweep generator.
SWEEP WIDTH switch -----	WIDE position provides 500 kHz to 400 MHz sweep of center frequency. NARROW position provides 10 kHz to 1 MHz sweep of center frequency.
SWEEP WIDTH control -----	Provides adjustment of sweep width within the range selected by the SWEEP WIDTH switch.
PHASING TURN-BLANKING PULL control/switch -----	<i>In</i> position permits adjusting of return trace on oscilloscope screen to coincide with forward trace. <i>Out</i> position blanks return trace.
MARKER GAIN PULL-TURN control:	
1 MHz switch/control -----	<i>In</i> position disables 1-MHz markers. <i>Out</i> position energizes 1-MHz markers and permits level adjustment.
10 MHz switch/control -----	<i>In</i> position disables 10-MHz markers. <i>Out</i> position energizes 10-MHz markers and permits level adjustment.
100 MHz switch/control -----	<i>In</i> position disables 100-MHz markers. <i>Out</i> position energizes 100-MHz markers and permits level adjustment.
MASTER GAIN-PULL EXT MKR switch/control -----	<i>In</i> position permits adjustment of amplitude level of all internal markers (1, 10, and 100 MHz) simultaneously. <i>Out</i> position connects external markers into the sweep generator, and permits adjustment level of all external and internal markers simultaneously.
FIXED CSC FREQ (screwdriver adjustment) -----	Provides fine adjustment to set vhf oscillator frequency at 600 MHz so that harmonic markers are accurate.
PREAMPLIFIER controls:	
BALANCE dual potentiometer (control knob and screwdriver adjustment accessible through center of control knob).	Permits adjustment of dc reference level of preamplifier output so that it is unaffected by the setting of the GAIN control. Screwdriver adjustment provides coarse control; knob provides fine control.
GAIN control -----	Adjusts preamplifier output voltage amplitude,
DC LEVEL control -----	Sets dc reference level on external oscilloscope (0 dc at zero rf level).
AC-DC switch -----	AC position provides ac coupling of preamplifier output to external oscilloscope. DC position provides dc coupling of preamplifier output to external oscilloscope.
WOBB DRIVE LIMIT potentiometer-screwdriver adjustment on top, rear of main chassis (fig. 2-1). Accessible by opening top lid of cabinet.	Protects wobblator unit by limiting voltage applied to it.
Input power switch (230V-115V switch bottom of main chassis (fig. 2-3)).	Permits operation from either 230 or 115 volts ac input power.

3-2. Types of Operation

a. Generator, Signal Sweep AN/USM-203 can be used for different applications where bandpass response or characteristics are required to be measured. Some of the most common applications of the sweep generator and oscilloscope are -

- (1) Measuring the bandpass of a receiver (para 3-6).
- (2) Measuring the bandpass of the RF section of a receiver (para 3-7).
- (3) Measuring the bandpass of the intermediate frequency (IF) section of a receiver (para 3-8).

- (4) Testing radiofrequency amplifiers (para 3-9).
- (5) Testing an individual amplifier stage (para 3-10).
- (6) Testing frequency response and measuring losses of filters and transformers (para 3-11).

(7) Measuring unloaded bandwidth and Q of cavities and resonant circuits (para 3-12).

(8) Testing load impedances for proper matching (para 3-13).

b. For any type of operation, perform the following procedures:

- (1) Oscilloscope connections (para 2-8).

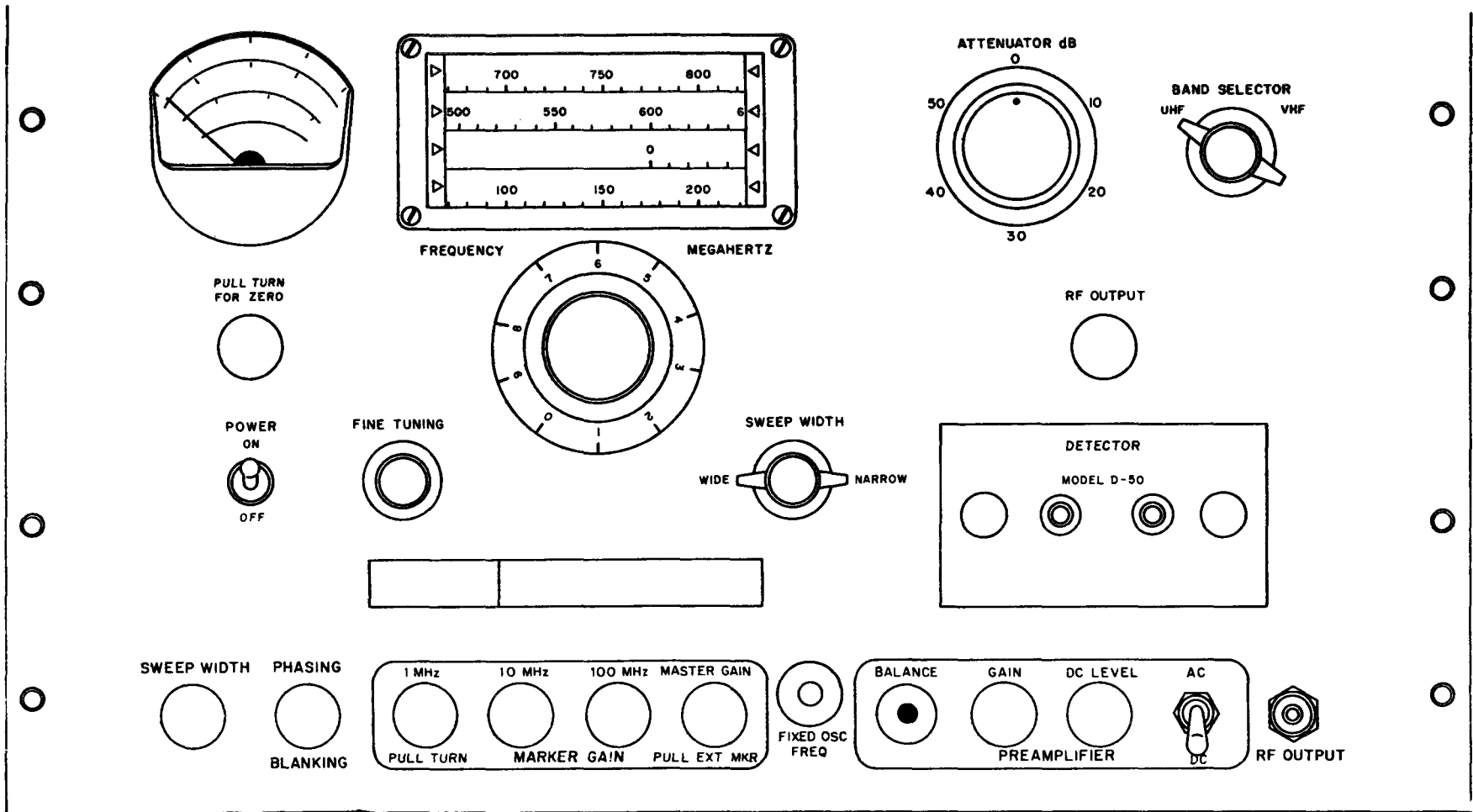

EL6625-1559-12-E

Figure 3-1. AN/USM-203, front panel controls and indicators.

(2) Starting procedure (para 3-3).

(3) Procedure for desired type of operation (para 3-6 through 3-13).

(4) Stopping procedure (para 3-15).

3-3. Starting Procedure

a. Preliminary.

(1) Set the front panel controls as follows (fig. 3-1):

Control	Position
PREAMPLIFIER controls:	
AC-DC switch -----	DC.
BALANCE control ----	Midrange.
GAIN control -----	Fully counterclockwise (minimum gain).
BAND SELECTOR switch -- UHF.	
SWEEP WIDTH switch.	WIDE.
SWEEP WIDTH control.	Fully clockwise (maximum sweep width).
RF OUTPUT control ---	Fully clockwise (maximum output).
ATTENUATOR db switch.	20.

(2) Insert shorting plug into EXT WOBB DRIVE socket on the rear panel of the main chassis (fig. 1-3).

b. Starting. Set the sweep generator POWER switch at ON, and turn on the oscilloscope. Allow a minimum 30-minute warmup period.

Note. It is important that no evaluation of sweep width be made before the 30-minute, warmup period, because the wobblator diaphragm is too stiff to make its maximum excursion while in the cold state. If the wobblator chatters at any time, by the WOBB DRIVE LIMIT control (fig. 2-2) counterclockwise until the noise stops. This control is a screwdriver adjustment located on top of the main chassis and is accessible by opening the top cover of the sweep generator cabinet. Chattering does not indicate a malfunction and no harm will result unless the chattering is permitted to continue for prolonged periods.

3-4 Initial Check of Equipment

a. Start the equipment (para 3-3).

b. Set the oscilloscope vertical sensitivity to 0.1 volt per centimeter and the horizontal sensitivity to 2 volts/cm. Center the trace on the screen.

c. Connect the SCOPE VERT jack on the rear of the sweep generator preamplifier chassis to the dc-coupled vertical input of the oscilloscope. If the trace disappears, return it to the reference

line established in *b* above by adjusting the PREAMPLIFIER DC LEVEL control.

d. Turn the PREAMPLIFIER GAIN control fully clockwise. If the trace moves, return it to the reference line by adjusting the *coarse* preamplifier balance potentiometer, a screwdriver adjustment accessible through the center of the PREAMPLIFIER BALANCE control knob.

e. Turn the PREAMPLIFIER GAIN control fully counterclockwise. If the trace moves, return it to the reference line by adjusting the PREAMPLIFIER DC LEVEL control.

f. Repeat the instructions in *d* and *e* above until the PREAMPLIFIER GAIN control can be rotated throughout its entire range without changing the position of the trace by more than 2 centimeters (cm). Use the front panel PREAMPLIFIER BALANCE (fine) control for finer adjustment.

g. Remove the connection to the oscilloscope vertical input. If the trace moves, adjust the PREAMPLIFIER DC LEVEL control until the trace remains in position whether or not the vertical input connection is made.

h. Reconnect the oscilloscope vertical input.

i. Pull the PHASING TURN-BLANKING PULL switch.

j. Connect the RF OUTPUT jack (fig. 3-1) to one input jack on the D-50 detector; use a short piece of high-quality, 50-ohm coaxial cable (RG-55/U, or equivalent). Terminate the unused input jack on the detector with the 50-ohm termination Adapter-Connector UG-1640/U supplied with the sweep generator.

k. Pull the 100 MHz MARKER GAIN switch.

l. Set the MARKER MASTER GAIN control for maximum gain (fully clockwise).

m. Turn the 100 MHz MARKER GAIN control clockwise until markers appear.

n. Push the PHASING TURN-BLANKING PULL switch in and observe the forward and return traces, each with a set of markers. Adjust the PHASING TURN-BLANKING PULL control so that the traces and markers approach coincidence.

o. Pull the PHASING TURN-BLANKING PULL switch.

p. Adjust the RF OUTPUT control to flatten the oscilloscope trace.

Note. Response should be within ± 0.5 decibel (db) from 0.5 to 800 MHz and within ± 1.5 db from 800 to 1,000 MHz. To check this, insert a high-quality, 1-db pad between the generator sweep output and the D-50 detector and note how far the trace falls. This action establishes a 1-db reference against which the response can be measured. Remove the pad after making the response check.

q. Using the 1-, 10-, and 100-MHz markers, check the range of the SWEEP WIDTH control. It should be from 500 kHz to 40 percent of center frequency. (Refer to para 3-5 for proper use of markers.)

Note 1. phasing must be readjusted (*m*, *n*, and *o* above) whenever the SWEEP WIDTH control setting is changed. If the specified maximum sweep width is not obtained, adjust the WOBB DRIVE LIMIT potentiometer clockwise until it is.

Note 2. If the 1-MHz markers are not visible or if they are off frequency, adjust the 1-MHz potentiometer on the harmonic marker chassis so that nine 1-MHz markers appear between any pair of 10-MHz markers.

r. Set the SWEEP WIDTH switch to NARROW and check the range of the SWEEP range should be from 10 kHz to 1 MHz.

s. Set the BAND SELECTOR switch to VHF.

t. Set the ATTENUATOR db switch to 0.

u. Set the SWEEP WIDTH control for maximum sweep width and adjust the phasing.

v. Set the RF OUTPUT control fully clockwise; then slowly turn it counterclockwise until the response trace flattens.

w. Check the range of the SWEEP WIDTH control; it should be at least 10 kHz to 1 MHz.

x. Pull the 100 MHz MARKER GAIN switch.

y. Tune the sweep generator to 0 MHz.

z. Adjust the FIXED OSC FREQ screwdriver adjustment on the front panel so that the 100-MHz marker is just off the center of the zero beat.

Note. The instructions in *z* above tunes the fixed oscillator just off 600 MHz. If the oscillator is tuned to precisely 600 MHz, its signal will mix with the sixth harmonic of the 100-MHz marker to generate an audio beat signal which will distort the trace display.

aa. Set the SWEEP WIDTH switch to WIDE.

ab. Adjust the SWEEP WIDTH control for maximum sweep width.

ac. Tune the sweep generator to position the zero beat at the extreme left of the display.

ad. Set the RF OUTPUT control fully clockwise, then slowly turn it counter-clockwise until the trace flattens.

ae. Using the 100-MHz markers, verify that the sweep width is at least 400 MHz.

Note. If the specified maximum sweep width is not obtained, adjust the WOBB DRIVE LIMIT potentiometer clockwise until it is.

3-5. Interpretation of Markers

Before using the sweep generator for actual equipment testing, the frequency marker system (birdy markers) must be understood and the interpretation of the various markers observed on the oscilloscope screen.

a. Internal Markers. The sweep generator provides internal markers at frequencies of 1, 10, and 100 MHz and all multiples of these frequencies within the range of the sweep generator. These markers are generated from a 5-megahertz (MHz) crystal-controlled oscillator and are extremely accurate. Separate amplitude controls are provided for each of the three sets of markers to allow rapid identification of the frequency represented by an individual marker. Perform the following operations and observe the actions of the markers (fig. 3-2).

(1) Set up the sweep generator and oscilloscope as described in paragraph 3-4a through h.

(2) Set the SWEEP WIDTH switch at WIDE.

(3) Connect the RF OUTPUT jack of the sweep generator through a 750-MHz resonant circuit to one input jack of the D-50 detector. Terminate the unused detector jack with Adapter-Connector UG-1640/U. Rotate the FREQUENCY MEGAHERTZ knob for a center frequency of 750 MHz, which sets up a basic response curve at 750 MHz. Observe the presentation on the oscilloscope screen. It should resemble the response shown in A, figure 3-2.

(4) Increase the sweep width by rotating the SWEEP WIDTH control until a narrow response curve presentation is observed similar to the response shown in B, figure 3-2.

(5) Push the PHASING TURN-BLANKING PULL switch in and observe the return trace and a double set of markers.

(6) Rotate the PHASING TURN-BLANKING PULL control until the top and bottom markers coincide on the oscilloscope screen.

(7) Pull the PHASING TURN-BLANKING PULL switch out to blank out the return trace and the markers on it.

(8) Pull the 100 MHz MARKER GAIN switch/control and rotate it clockwise until markers are visible and resemble the response at B, figure 3-2.

(9) Observe that the peak of the response curve is between two markers which can be iden-

tified as 700 and 800 MHz. (The markers are on integral 100-MHz points and the center frequency of the response curve was chosen as 750 MHz; therefore, the identification of the two markers bridging the response curve is 700 and 800 MHz.)

(10) Pull the 10 MHz MARKER GAIN switch/control and rotate it clockwise until the markers are visible and resemble the response at C, figure 3-2. Set the 10-MHz markers slightly smaller in amplitude than the 100-MHz markers to enable them to be easily identified.

(11) Observe that the peak of the response curve is between two markers representing 740 and 750 MHz, respectively. Start with the large 100-MHz marker representing 700 MHz at the left edge of the screen, and count each 10-MHz marker until the markers representing 740 and 750 MHz are reached.

(12) Decrease the sweep width by rotating the SWEEP WIDTH control counterclockwise until the 740- and 750-MHz markers are near the left and right edges of the oscilloscope screen, respectively. Adjust the BLANKING and PHASING controls as described in (5), (6), and (7) above.

(13) Pull the 1 MHz MARKER GAIN switch/control and rotate it clockwise until the markers are visible and resemble the response at D, figure 3-2. Set the 1-MHz markers slightly smaller in amplitude than the 10-MHz markers to enable them to be easily identified.

(14) Observe that the peak of the response curve falls between the seventh and eighth 1-MHz markers, representing 747 and 748 MHz. If necessary, adjust the horizontal amplifier and horizontal position controls on the oscilloscope to facilitate this observation.

(15) If a finer frequency determination is required, decrease the sweep width further by rotating the SWEEP WIDTH control counterclockwise until the 1-MHz markers representing 747 and 748 MHz are at the left and right edges of the oscilloscope screen, coinciding with the edges of the centimeter grid. Estimate 0.1-MHz points on the response curve by observing the intersection of the grid lines with the response curve.

b. External Markers. The sweep generator has provision for the use of markers derived from external equipment. For checking certain types of equipment, such as bandpass filters or television receivers, specific fixed marker frequencies are provided for the connections of external markers. These jacks are located on the rear

panel of the main chassis and are labeled EXTERNAL MARKERS. Connect and interpret the external markers as follows:

(1) Connect the output of the external marker source to one of the EXTERNAL MARKERS jacks. A signal of more than 20 millivolts is required.

(2) Push the MARKER GAIN 1 MHz, 10 MHz, and 100 MHz switch/controls in. This action disables the internal markers.

(3) Pull the MASTER GAIN-PULL EXT MKR switch/control. This action connects the external marker source to the marker amplifier.

(4) Adjust the MASTER GAIN control until the markers are visible on the oscilloscope pattern.

c. Adjusting for Clearest External Fundamental Markers. Where a marker is derived from the fundamental frequency of the external marker source, obtain the clearest presentation of the markers as follows:

(1) Set the output control of the external marker source to the lowest setting that will give a suitable signal.

(2) Set the MASTER GAIN-PULL EXT MKR control on the sweep generator to as high a setting as required to provide usable markers on the oscilloscope screen. The response should now resemble that shown at A, figure 3-3.

d. Adjusting for Clearest External Harmonic Markers. When a marker is derived from a harmonic frequency of the external marker source, present the sharpest markers as follows:

(1) Set the MASTER GAIN-PULL EXT MKR control at a relatively low setting.

(2) Set the output control of the external marker source as high as practical without making the amplitude of the markers more than 15 percent of the total height of the response curve. Refer to figure 3-2 for typical examples.

e. Sideband Markers. Where a bandpass response curve is to be observed, it is often convenient to provide frequency markers at the upper, center, and lower frequency limits of the desired band of frequencies. Do this as follows:

(1) Use two external marker sources, one with a frequency at the center of the band to be observed, and the other with a frequency equal to one-half the bandwidth of the frequency band to be observed.

(2) Connect these signals to the two EXTERNAL MARKERS jacks at the rear of the sweep generator.

(3) Pull the MASTER GAIN-PULL EXT MKR switch/control and adjust it, in conjunction with the output controls of the external center frequency marker source, until the oscilloscope display resembles that shown in B, figure 3-3.

(4) Adjust the output controls of the external one-half bandwidth marker source until the oscilloscope display resembles that shown in C, figure 3-8.

3-6. Measuring Bandpass of Receiver (fig. 3-4)

Measure the overall bandwidth of a complete receiver as follows:

a. Connect the RF OUTPUT jack of the sweep generator to the input terminals of the receiver through a matching pad, balun, or dummy antenna as required.

b. Determine a suitable point in the receiver second detector circuit to obtain a rectified output voltage. If this voltage is 0.1 volt peak-to-peak or more, connect it directly to the vertical amplifier input terminals of the oscilloscope; observe correct ground polarity. Connect a 50-micromicrofarad (uuf) capacitor, from the SCOPE VERT jack on the rear of the sweep generator to the ungrounded vertical amplifier input terminal to the oscilloscope, to couple the frequency marker signals to the oscilloscope.

c. If the receiver output voltage obtained as instructed in *b* above is less than 0.1 volt peak-to-peak, connect it to the EXT DET jack at the rear of the sweep generator. This action amplifies the receiver output signal and produces a readable oscilloscope pattern.

d. If the receiver has automatic gain control (agc), disable it and substitute a manually varied bias control. The exact procedure depends on the particular type of receiver being tested.

e. Turn on the receiver and allow it to warm up long enough to become stable.

f. Set the FREQUENCY MEGAHERTZ dial on the sweep generator to the same center frequency as that of the receiver.

g. A pattern should appear on the oscilloscope screen; if not, adjust the PREAMPLIFIER BALANCE control and/or DC LEVEL control until a pattern does appear.

h. Balance the preamplifier for direct current (dc) by rotating the PREAMPLIFIER GAIN control back and forth. Adjust the PREAMPLIFIER BALANCE control to keep the pattern on the oscilloscope screen until the PREAMPLIFIER GAIN control can be rotated throughout

its entire range while the pattern on the oscilloscope screen remains stationary.

i. Adjust the PREAMPLIFIER DC LEVEL control to set the position of the baseline on the oscilloscope for best presentation.

j. Set the SWEEP WIDTH switch and the SWEEP WIDTH control just wide enough to show the entire response curve of the receiver. Observe the phasing precautions in paragraph 3-2a(5), (6), and (7).

k. Check the oscilloscope pattern for distortion by increasing the ATTENUATOR db control on the sweep generator by 10 decibels. Move the ATTENUATOR db control to a setting 10 db higher than the one in use. If the shape (not amplitude) of the pattern changes significantly, overload distortion is indicated.

l. If distortion is present, reduce the input to the receiver and increase the setting of either the PREAMPLIFIER GAIN control on the sweep generator, or the vertical amplifier gain control on the oscilloscope, or both, until the test in *k* above indicates no distortion on the pattern. If necessary, insert an external 20-db attenuator between the RF OUTPUT jack and the test cable to the receiver input (fig. 3-4).

m. Observe the pattern on the oscilloscope screen; make adjustments and bandwidth measurements as described in paragraph 3-2.

n. Where sudden changes are present in the response curve of the receiver circuit, such as highly selective traps to remove specific frequencies, the sweep may move past these traps too rapidly for the detector to follow accurately. For a more accurate display, decrease the SWEEP WIDTH control and shift the FREQUENCY MEGAHERTZ dial to cover only this small section of the response curve.

o. When the receiver circuit contains rejection notches or other sharp changes in the response curve, spurious component may be generated in the amplifiers of the sweep generator or the oscilloscope. These notches or changes will show up as extraneous markers on the response curve and can be distinguished from normal markers by reducing the setting of the RF OUTPUT control. Normal marker signals will be reduced proportionally; extraneous markers will tend to disappear completely. Whenever possible, use reduced RF OUTPUT control settings of the sweep generator when the response curve contains sharp components.

p. When specific band-edge and band-center markers are required from an external source, re-

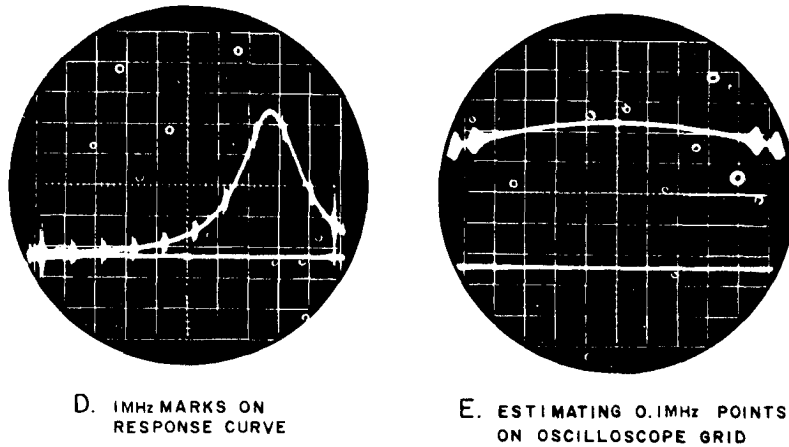
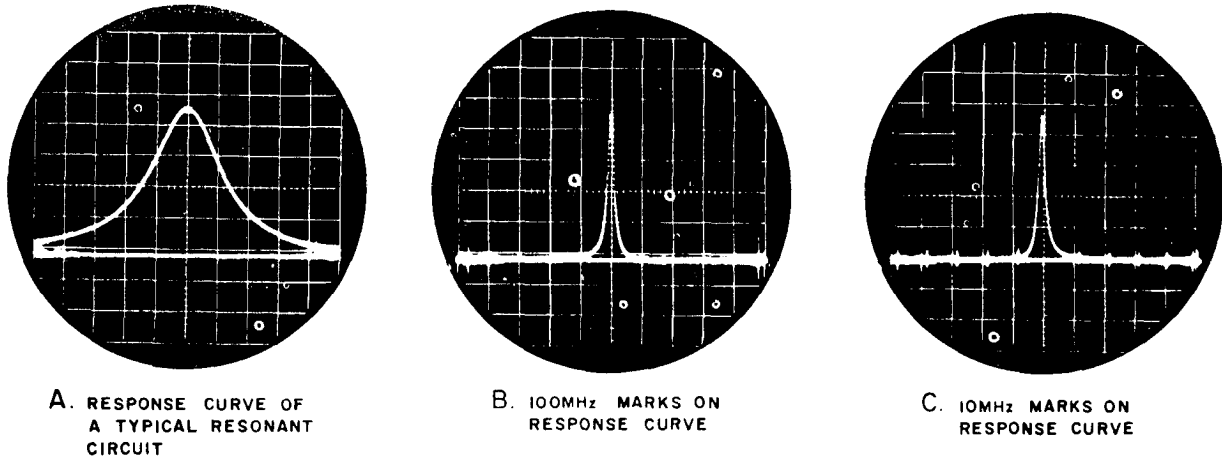

EL6625-1559-12-7

Figure 3-2. Typical oscilloscope display using internal markers.

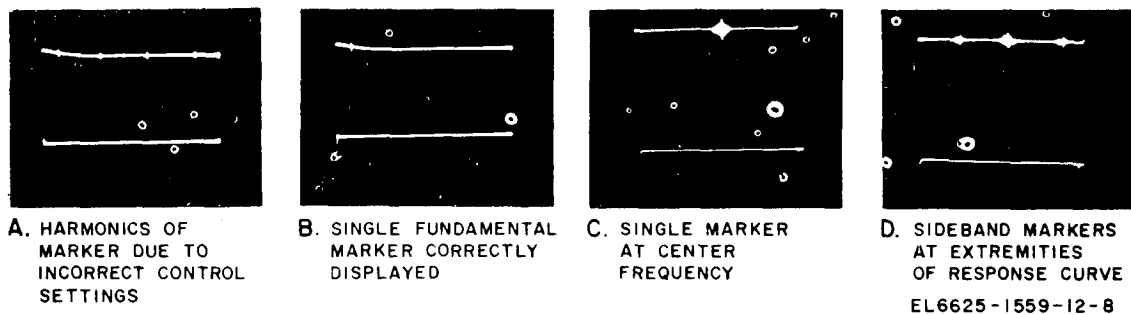

EL6625-1559-12-8

Figure 3-3. Typical oscilloscope display using external markers.

fer to paragraph 3-5b through e for the correct procedure for using external markers.

3-7. Measuring Bandpass of RF Section of Receiver
(fig. 3-5)

a. *Bandpass Measurement.* The response curve of the RF portion only of a receiver may be analyzed by following the procedures in (1) through (6) below.

(1) Connect the RF OUTPUT jack of the sweep generator to the input terminals of the receiver through a matching pad; balun, or dummy antenna, as required.

(2) Connect a suitably shielded output cable from the EXT DET jack to the dc load resistor of the receiver mixer. (This connection may be a test point on the receiver.)

(3) Perform the procedure in paragraph 3-6d through 1, to obtain the best display on the oscilloscope screen.

(4) Keep the setting of the RF OUTPUT control as high as possible without causing distortion, but keep at least 10 db of attenuation on the ATTENUATOR db control to provide a proper impedance match to the input of the receiver.

(5) Observe the pattern on the oscilloscope screen; make adjustments and measurements as described in paragraph 3-5.

(6) If the response curve has sharp changes, perform the procedure in paragraph 3-6n, o, and p.

b. *Eliminate of Hum.* If the forward and return traces cannot be brought into coincidence when phasing is attempted, the trouble is proba-

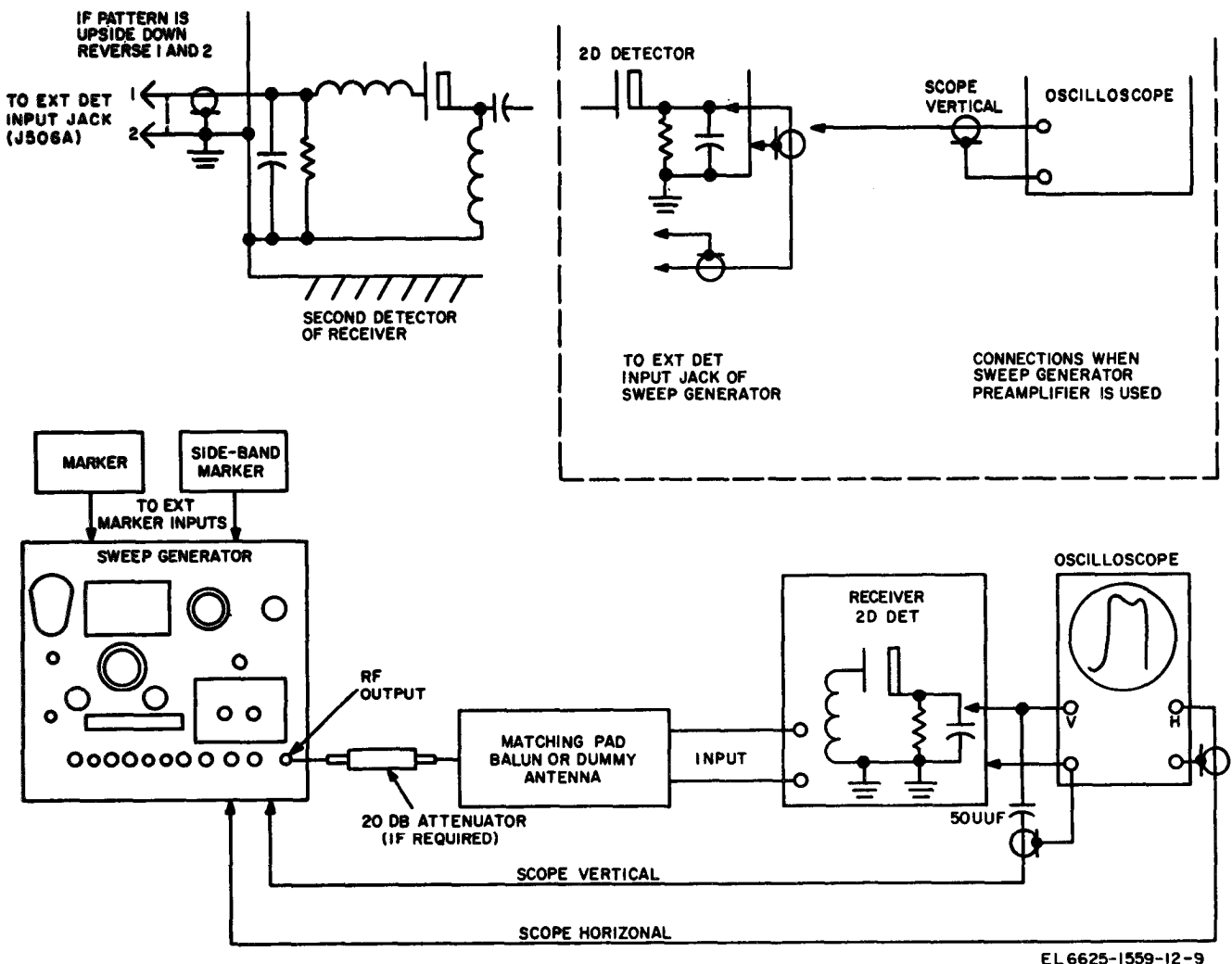

EL 6625-1559-12-9

Figure 3-4. Setup for testing complete receiver.

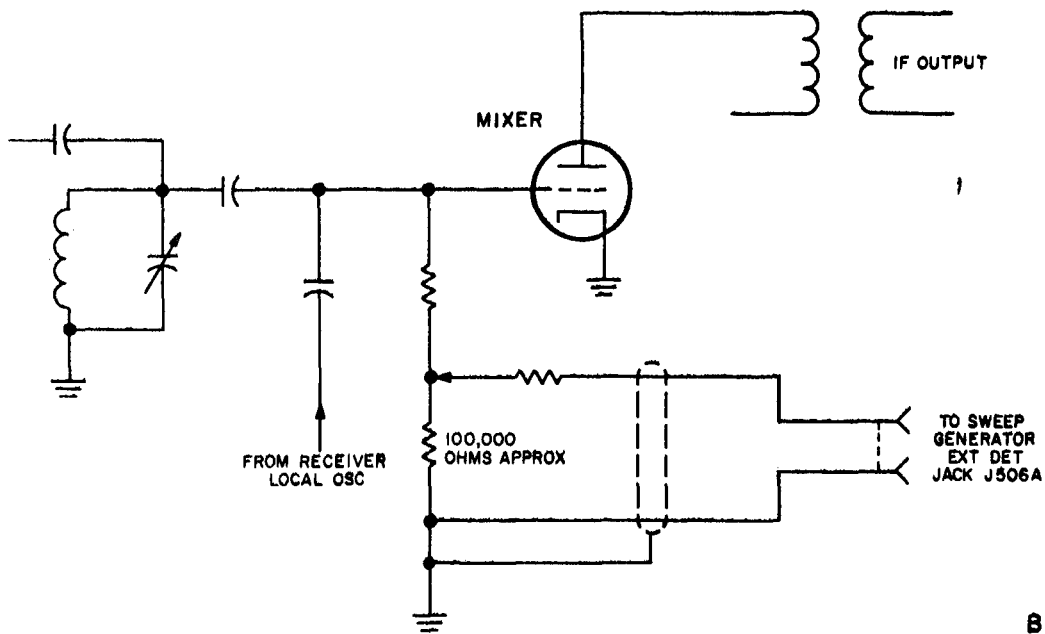
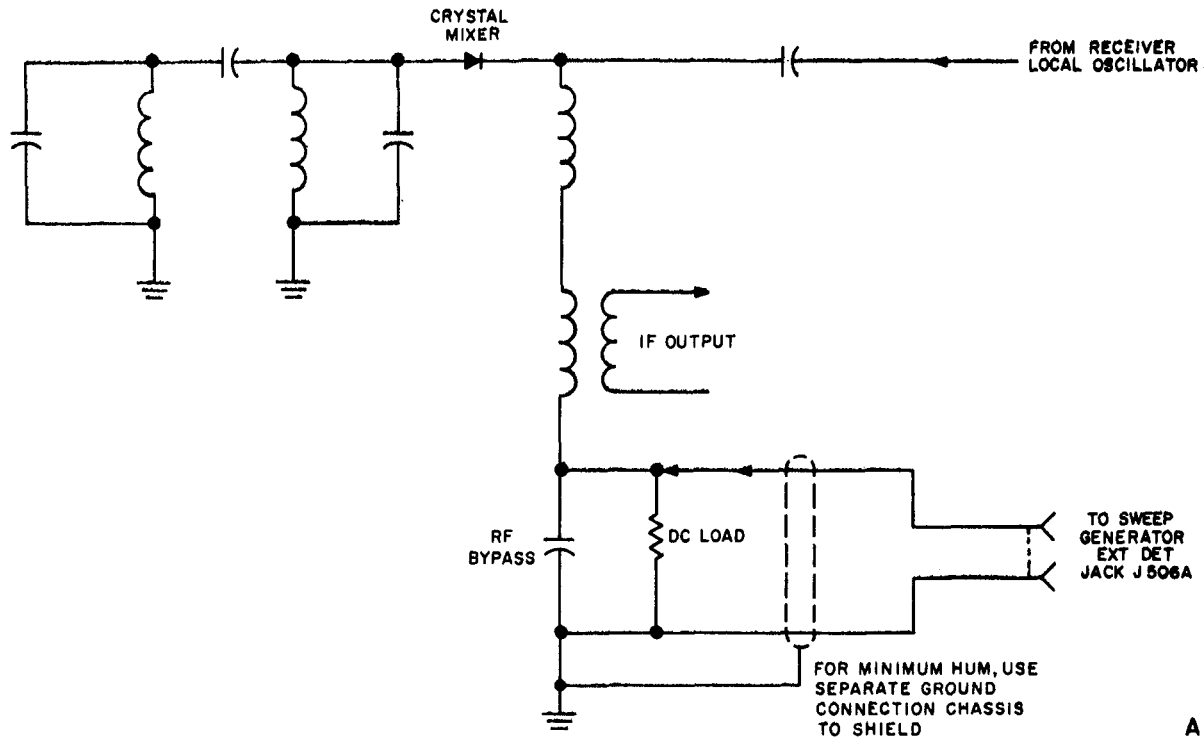

EL 6625-1559-12-10

Figure 3-5. Setup for testing RF section of receiver.

bly caused by the existence of hum voltage at the EXT DET jack. Determine if the hum voltage originates in the local oscillator stage of the receiver by temporarily disabling the oscillator. If the hum stops, restore the operation of the

local oscillator and proceed as follows to reduce or eliminate this hum voltage:

- (1) Make up a special test cable consisting of two separately shielded leads, or two leads in an individual shield.

(2) Connect one lead to the center pin of a UG-88/U connector.

(8) Connect the other lead to the shell of the UG-88/U connector. Do not connect the shield to any portion of the connector.

(4) Substitute this special cable for the output cable described in *a(2)* above.

(5) Ground the shielding of the test cable to various points on the receiver chassis until a point of minimum hum pickup is found.

(6) Ground the other end of the shielding to various points on the sweep generator chassis to see if further reduction of the hum voltage can be effected.

(7) Use the combination of ground connections which results in the least amount of hum voltage.

Note. Use all means available to reduce the hum rather than make the test with the receiver local oscillator disabled, because the local oscillator excitation affects the input impedance of the receiver mixer input stage and alters the shape of the response curve.

3-8. Measuring BandPass of IF Section of Receiver (fig. 3-6)

The response curve of the IF portion only of a receiver may be analyzed as follows:

a. Connect the sweep generator to the receiver (para 3-6*b* through *j* and fig. 3-4).

b. Connect the RF OUTPUT jack to the output of the receiver mixer tube for reasonably uniform response without changing the output impedance of the mixer state. A recommended method is shown in figure 3-6, where the RF OUTPUT jack of the sweep generator is connected to a 50-ohm terminating resistor at the output of the receiver mixer stage.

c. Couple the RF OUTPUT voltage of the sweep generator loosely to the receiver mixer output to avoid changing the tuning of the mixer plate circuit.

Note. It is important to introduce the signal from the sweep generator to the receiver mixer stage by a method that does not result in added overall feedback in the receiver IF circuits. Ground the outer shield of the test cable from the sweep generator carefully to the chassis of the receiver near the mixer stage. If the frequency is above 10 MHz, attach the test cable to a connection which brings it through the chassis, using the chassis as a shield against unwanted feedback fields.

d. Perform the procedure described in paragraph 3-6*d* through *l*, to obtain the best display on the oscilloscope screen.

e. Observe the pattern on the oscilloscope screen; make adjustments and measurements as described in 3-6.

3-9. Testing Radiofrequency Amplifiers (fig. 3-7)

a. Analyzing Amplifier Response. The response curve of an rf amplifier operating within the 500-kHz to 1,200-MHz range may be analyzed as follows:

(1) Connect the RF OUTPUT jack of the sweep generator to the input terminals of the amplifier under test; use a matching pad if the input impedance of the amplifier differs from the output impedance (50 ohms) of the sweep generator.

(2) Connect the output of the amplifier under test to one of the DETECTOR jacks on the front panel of the sweep generator; use a matching pad if the output of the amplifier is designed for other than 50 ohms.

(3) Terminate the other DETECTOR jack with adapter-connector UG-1640/U, furnished with the sweep generator.

(4) Perform the procedure described in paragraph 3-6*d* through *l*, to obtain the best pattern on the oscilloscope screen.

(5) For bandwidth and response curve measurements, make the adjustments and measurement described in paragraph 3-5.

(6) If the response curve has sharp changes, refer to paragraph 3-6*n*, *o*, and *p*.

b. Measurement of Amplifier Gain. The gain of any portion of the response curve of the amplifier under test may be measured as follows:

(1) With the equipment set up as described in *a* above, disconnect the test cables from the amplifier under test. Keep the matching pads attached to the test cables.

(2) Connect the two cable ends together, including the matching pads, so that the input cable feeds through both matching pads into the output cable.

(3) Set the ATTENUATOR db control on the sweep generator to 0.

(4) Adjust the RF OUTPUT control until the VOLTS meter reads 0 DBM on its bottom scale.

(5) With the PHASING TURN-BLANKING PULL switch pulled out, adjust the oscilloscope vertical amplifier gain control so that the desired portion of the response curve is at a convenient distance from the baseline (about 5 centimeters). Note this distance.

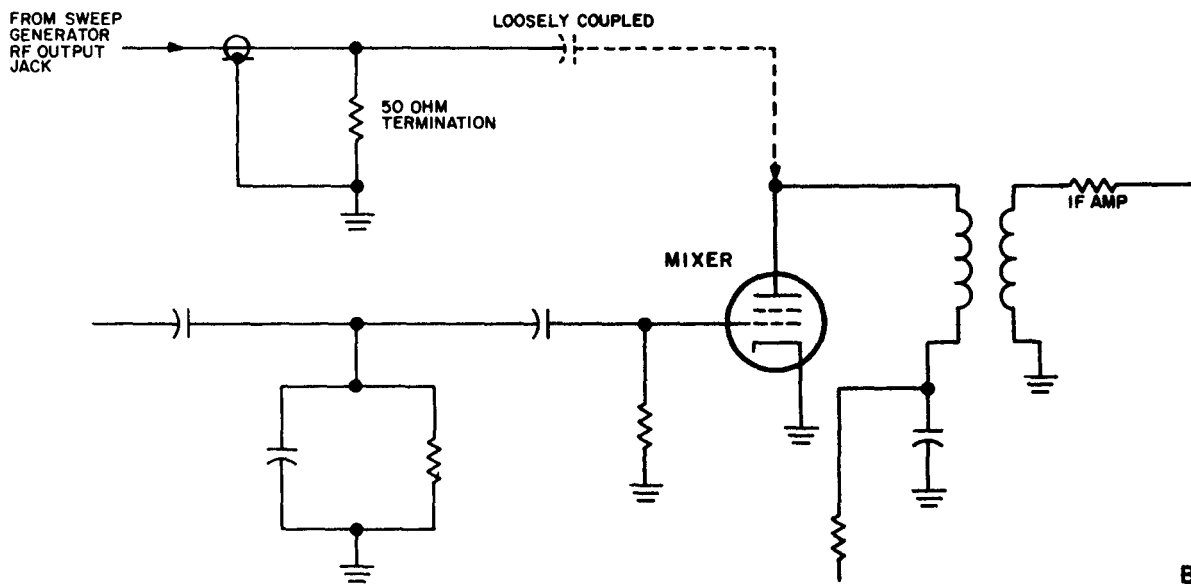
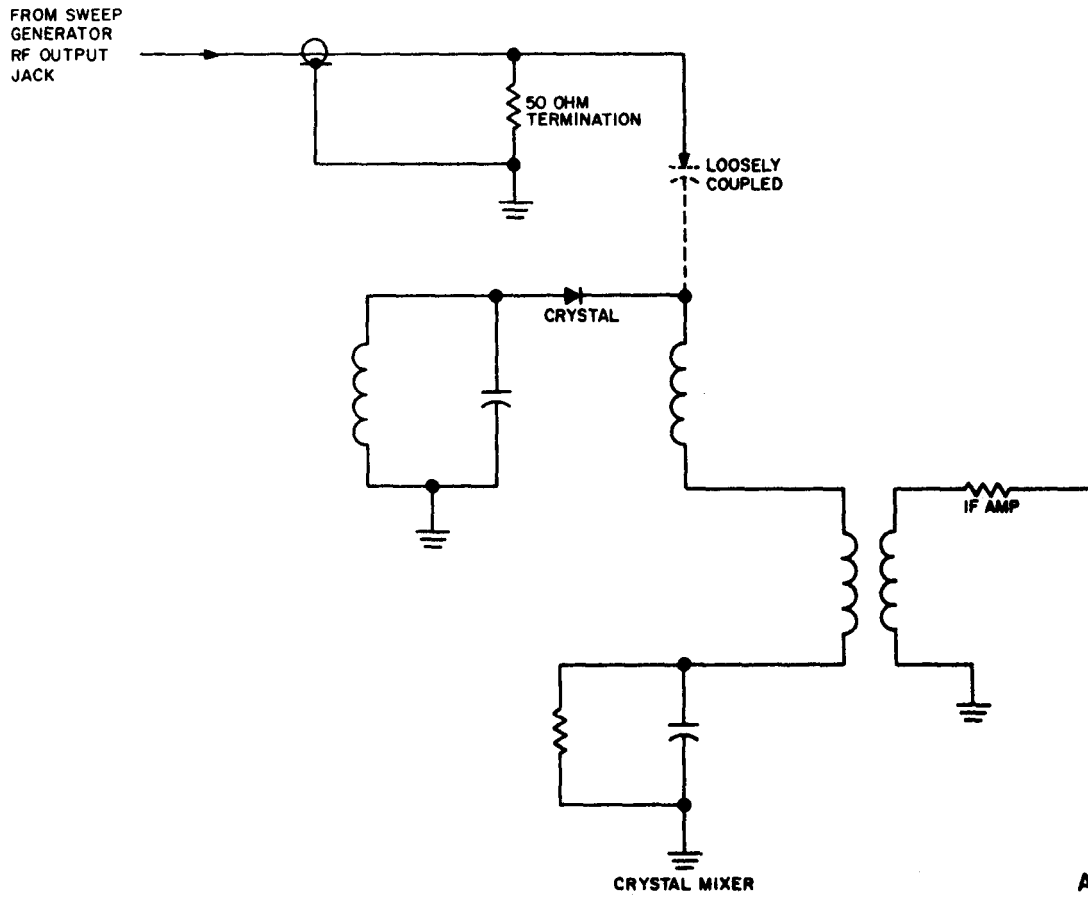

EL 6625-1559-12-11

Figure 3-6. Setup for testing IF section of receiver.

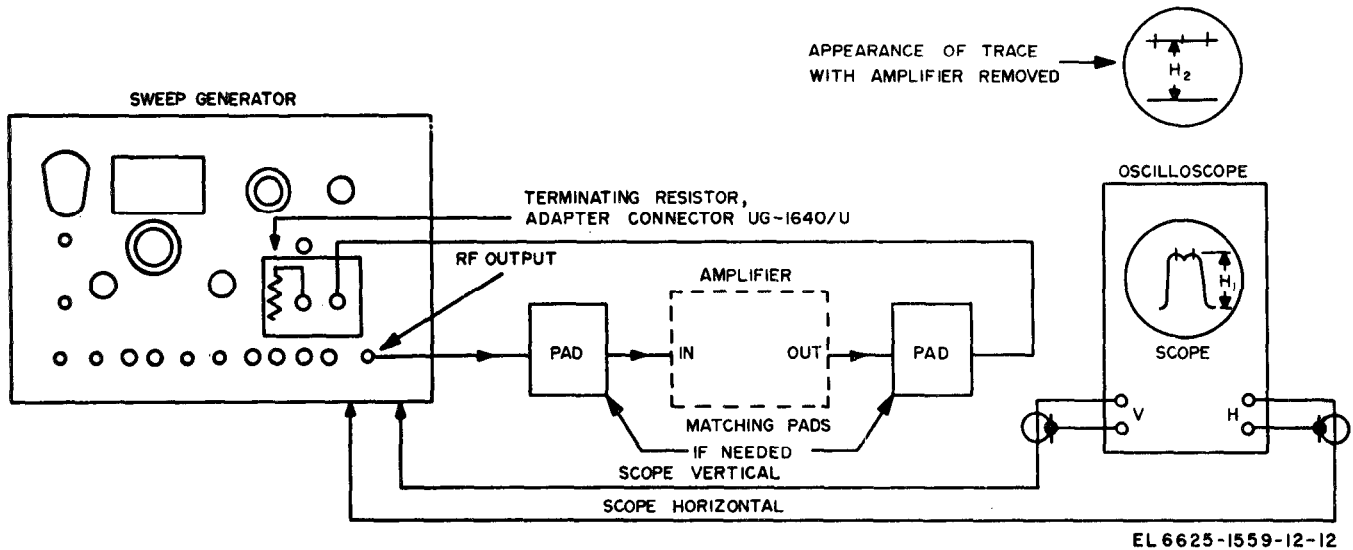

Figure 3-7. Setup for testing RF amplifier.

(6) Reconnect the amplifier input and output terminals to the test cables. Do not make any adjustments, even if the oscilloscope pattern leaves the screen.

(7) Adjust the ATTENUATOR db control on the sweep generator clockwise until the response curve on the oscilloscope screen returns to a point slightly higher than the position noted in (5) above.

(8) Adjust the RF OUTPUT control on the sweep generator counterclockwise until the response curve height is exactly at the position noted in (5) above.

(9) The decibel gain of the amplifier under test is determined by the combined readings of the ATTENUATOR db dial and the DBM reading on the VOLTS meter. For example, if the ATTENUATOR db dial is on 30 and the VOLTS meter reads -6DBM, the amplifier gain is 36 decibels.

3-10. Testing Individual Stage in Amplifier

The sweep generator may be used to test an individual stage in an amplifier. To do this, connections to the input and output circuits of the individual stage must be made by a method that does not affect its frequency response. Two methods of making this connection are described below. The choice of method depends upon the circuitry of the amplifier to be tested.

a. Method I (A, fig. 3-8). Method I connects to the individual stage directly. Perform the following procedure.

(1) Connect the RF OUTPUT jack through a test cable to the grid of the tube preceding the stage to be tested, in series with a 10-uuf capacitor. Keep the connections as short as possible.

(2) Insert a 6- to 10-db attenuator in the test cable for a better response curve presentation.

(3) Connect the output of the stage to be tested through a 10-uuf capacitor and a test cable to one DETECTOR jack on the sweep generator. Terminate the other DETECTOR jack with Adapter-Connector UG-1640/U.

(4) Perform the procedure described in paragraph 3-6 *d* through *l*, to obtain the best display on the oscilloscope screen.

(5) Observe the pattern on the oscilloscope screen; make adjustments and measurements as described in paragraph 3-5.

b. Method II (B, fig. 3-8). Method II is used if the individual stage to be tested is part of a feedback circuit involving other stages. This method requires the use of a broadband amplifier with a response that is flat beyond the frequency limits of the particular stage to be tested. Make measurements as follows:

(1) Connect the RF OUTPUT jack of the sweep generator through a test cable to the output of the stage preceding the one being tested. Use a series capacitor small enough to have negligible loading effect on the circuit but large enough to give an adequate response curve dis-

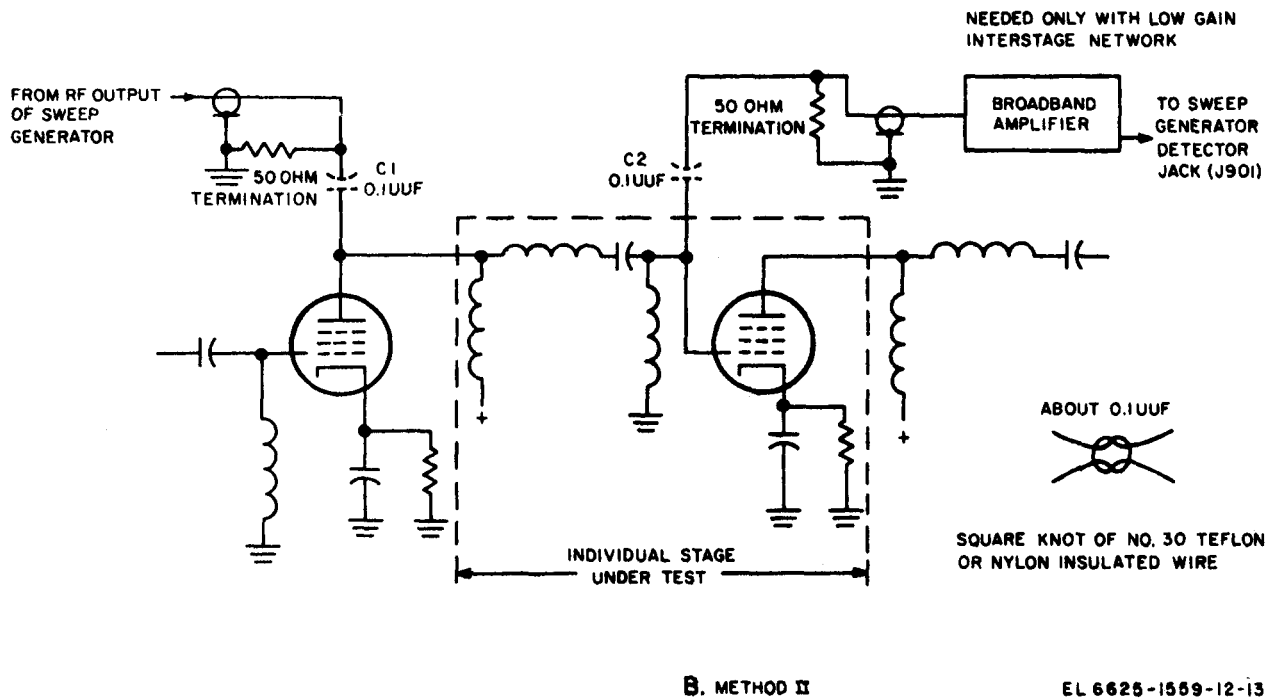
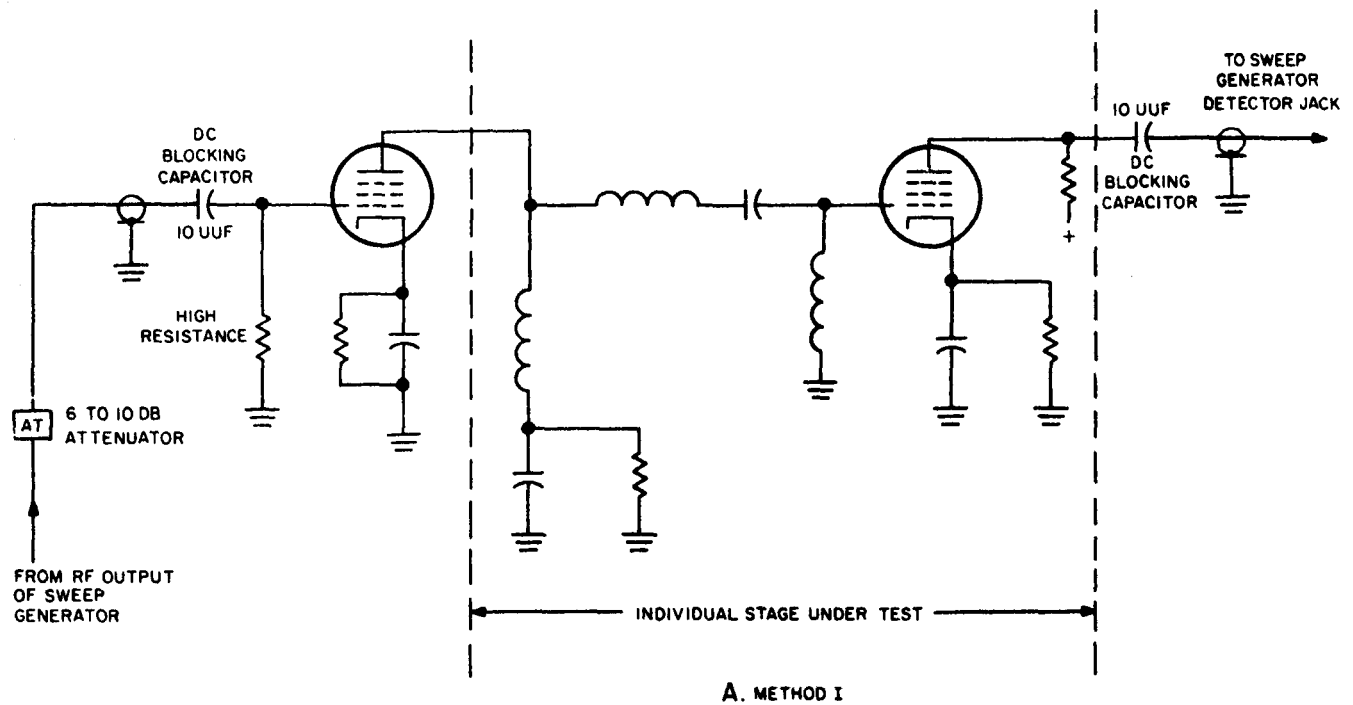

EL 6625-1559-12-13

Figure 3-8. Setup for testing individual stage in amplifier.

play. (A capacitance of about 0.1 uuf may be obtained by tying a square knot with two pieces of teflon-insulated hookup wire.)

Note. Any coupling method which uses small values

of capacitance must be used only with relatively narrow-band circuits (10 percent deviation from center frequency, or less). With wide-band amplifiers, the response curve display will be tilted, because of the reactance of the coupling capacitor.

(2) Connect the output of the transformer or coupling device of the stage being tested to the input of the auxiliary broad-band amplifier; again using a small capacitor such as that described in (1) above. Be careful to prevent stray pickup from nearby circuitry.

(3) Connect the output of the auxiliary broadband amplifier to one DETECTOR jack on the sweep generator; terminate the other DETECTOR jack with Adapter-Connector UG-1640/U. If the output impedance of the broadband amplifier is not 50 ohms, use a matching pad.

(4) Perform the procedure described in paragraph 3-6d through 1, to obtain the best display on the oscilloscope screen.

(5) Check the effects of the feedback circuits on the stage being tested. Vary the gain of the tube preceding the stage; if the oscilloscope pattern changes, feedback originates in the earlier stages. Vary the gain of the tube following the stage; if the oscilloscope pattern changes, feedback originates in the later stages of the amplifier under test.

(6) Observe the pattern on the oscilloscope screen; make adjustments and measurement as described in paragraph 3-5.

(7) When the individual stage to be tested is an input or output stage of an amplifier, neither of the above methods will give complete satisfactory results. The use of a voltage comparator will provide a more accurate and convenient method of marking such tests.

3-11. Testing Frequency Response and Measuring Loss of Filters or Transformers (fig. 3-9)

The general technique for testing radiofrequency components is similar to that used for amplifiers. Components such as filters and transformers have no self-contained amplification; therefore, more system gain is required. The available output voltage and the sensitivity of the preamplifier circuits of the sweep generator will handle insertion losses up to 50 decibels. For higher losses, an auxiliary amplifier is required that has sufficient gain to compensate for these losses and sufficient bandwidth to cover the frequency response range of the item to be tested.

a. Make the same connections to the sweep generator, and use the same procedure to measure the bandwidth and gain, as for amplifiers (para 3-9).

b. When a filter under test has deep rejection notches within an octave band, the distortion of the oscilloscope display can be minimized by the use of an auxiliary low-pass filter that is set to cut off just above the octave band. Also, use the lowest setting of the RF OUTPUT control that will provide an adequate display of the response curve.

c. Transformers the secondary impedance of which differs from the primary impedance may be tested by using two transformers connected back to back as shown. However, if the transformers are not identical, the response curve will represent the composite response of both transformers rather than the curve of an individual unit.

3-12. Measuring Unloaded Bandwidth and Q of Cavities or Resonant Circuits (fig. 3-10)

The sweep generator may be used to analyze extremely narrow-band radiofrequency components, such as resonant cavities and high-Q tuned circuits. Make these measurements as follows:

a. Connect the input of the cavity to be tested to the RF OUTPUT jack through a test cable. Use a loose coupling method.

b. Connect the output of the cavity through a test cable to one of the DETECTOR jacks on the sweep generator. Terminate the other DETECTOR jack with Adapter-Connector UG-1640/U. Again use a loose coupling method.

c. If the device to be tested is a tuned circuit and does not have a self-contained coupling loop, make up a small coupling loop for use as an input circuit. Use a small capacitor to couple the test cable to the output of the tuned circuit.

Note. It is important to use the least coupling that will provide adequate observation of the response curve. In general, when the coupling gives an insertion loss of 20 db as compared to a direct connection, an error of 5 percent can be expected in the bandwidth. With an insertion loss of 40 db, the bandwidth error is reduced to 1 percent.

d. Perform the procedure described in paragraph 3-6d through 1, to obtain the best display on the oscilloscope screen.

e. Be careful, to prevent any stray coupling between the two test cables. No response curve should be displayed on the oscilloscope with the cavity or tuned circuit completely detuned or shorted out. If various physical placements of the test cables do not completely eliminate the stray coupling, use inductive coupling from one cable to the cavity and capacitive coupling to the other.

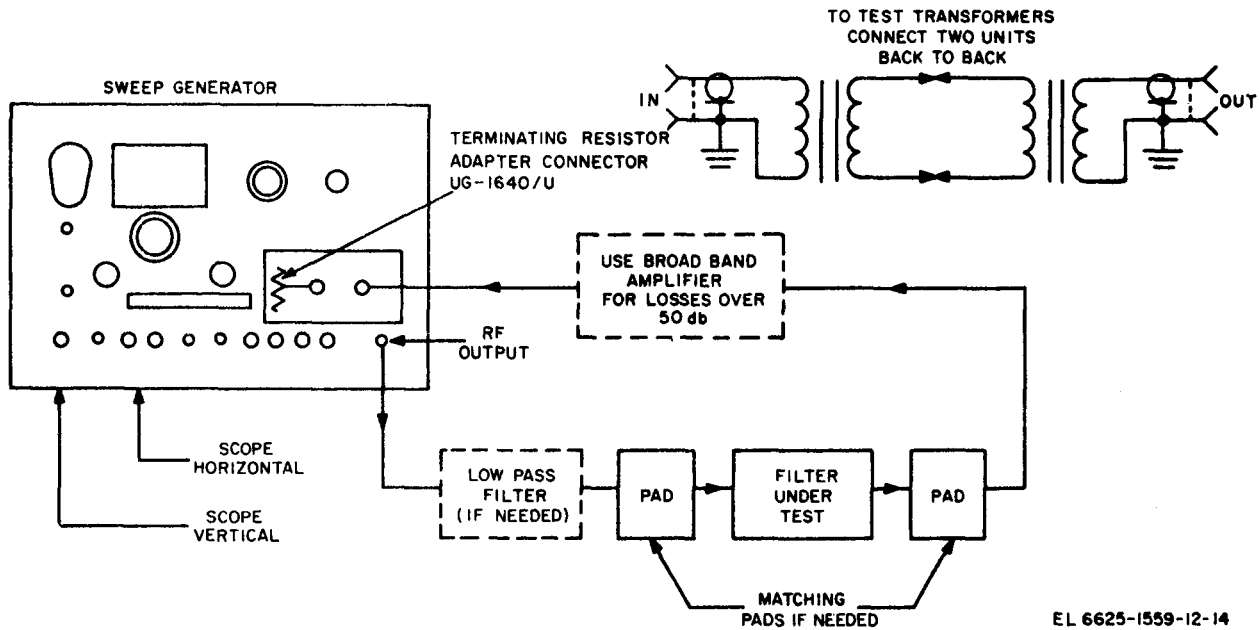

EL 6625-1559-12-14

Figure 3-9. Setup for testing filters or transformers.

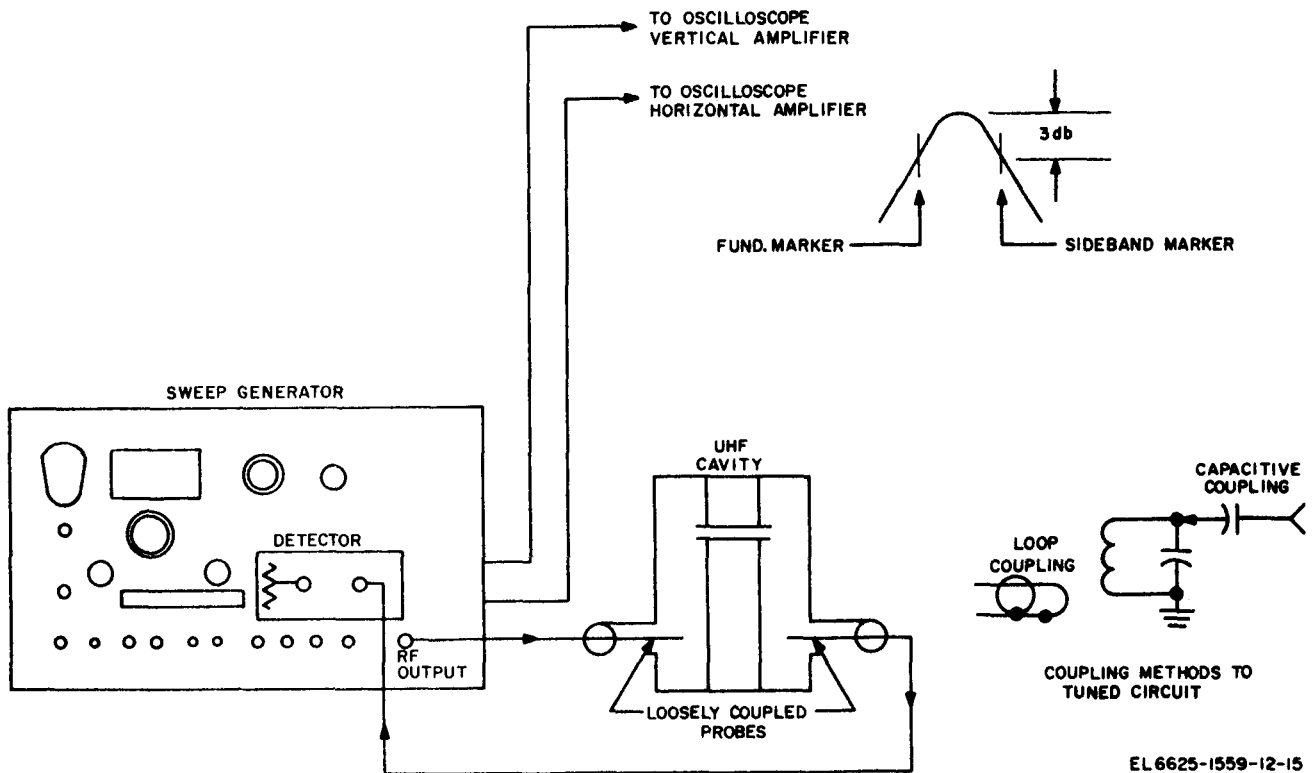

EL 6625-1559-12-15

Figure 3-10. Setup for testing cavities and resonant circuits.

f. For a precise measurement of bandwidth, use external sideband markers (para 3-5e).

g. Observe the pattern on the oscilloscope screen; make adjustments and measurements as described in paragraph 3-5.

3-13. Testing Lead Impedances for Proper Matching (A, fig. 3-11)

The proper matching and the frequency response of an impedance termination of a transmission

line system may be measured by the sweep generator and a delay line, which can be made up from coaxial cable, the type and dimensions depending upon the frequency range and the particular type of impedance to be tested. Make this measurement as follows:

a. Connect the sweep generator RF OUTPUT jack to one of the DETECTOR input jacks; use a short length of test cable with UG-88/U connectors.

b. Connect the other DETECTOR jack to a delay line made up of low-loss 50-ohm coaxial cable. The length of this cable should be long enough to include approximately 8 to 10 half-waves of the frequency being measured.

Note. A half-wavelength of cable may be calculated by using either of the following formulas:

(1) For solid polyethylene cables:

$$\text{Length in feet} = \frac{333}{\text{Frequency in MHz}}$$

(2) For aid dielectric cables:

$$\text{Length in feet} = \frac{492}{\text{Frequency in MHz}}$$

c. Follow the procedure in paragraph 3-6d through l, to obtain the best display on the oscilloscope screen.

d. Observe the oscilloscope display and compare it with that shown at B, figure 3-11. The loops represent standing waves reflected back from the open end of the cable, the number of loops depending upon the frequency and length of cable. A pattern that resembles that shown

at C figure 3-11 will be observed when the far end of the cable is short-circuited.

e. Terminate the far end of the delay line with the impedance to be analyzed. Use the proper fittings to avoid any additional mismatch problems.

f. If the impedance termination is resistive or broadband and matches the impedance of the delay line, the loops will straighten out into a nearly straight line as shown at D, figure 3-11.

g. If the impedance has only a narrow-band matching characteristic, only a few of the loops will be straightened out, corresponding to the frequencies at which the delay line is matched, as shown at E, figure 3-11.

3-14. Use of External Wobbulator Drive Frequencies

If other than the built-in 60-cycle sweep frequency is required for special tests, an external drive voltage may be connected at the rear of the power supply chassis, as follows:

a. Disconnect the jumper from terminals 2 and 3 on the EXT WOBB DRIVE terminal strip.

b. Connect an external sweep voltage, from dc to 60 cycles, not to exceed 3 volts, between terminals 1 and 2 of the terminal strip.

c. The maximum and minimum sweep widths obtainable from this external voltage may still be controlled with the SWEEP WIDTH switch and SWEEP WIDTH control on the sweep generator.

3-15. Stopping Procedure

a. Set the POWER switch to OFF position.

b. Push PHASING TURN-BLANKING PULL and MARKER GAIN switches to in position.

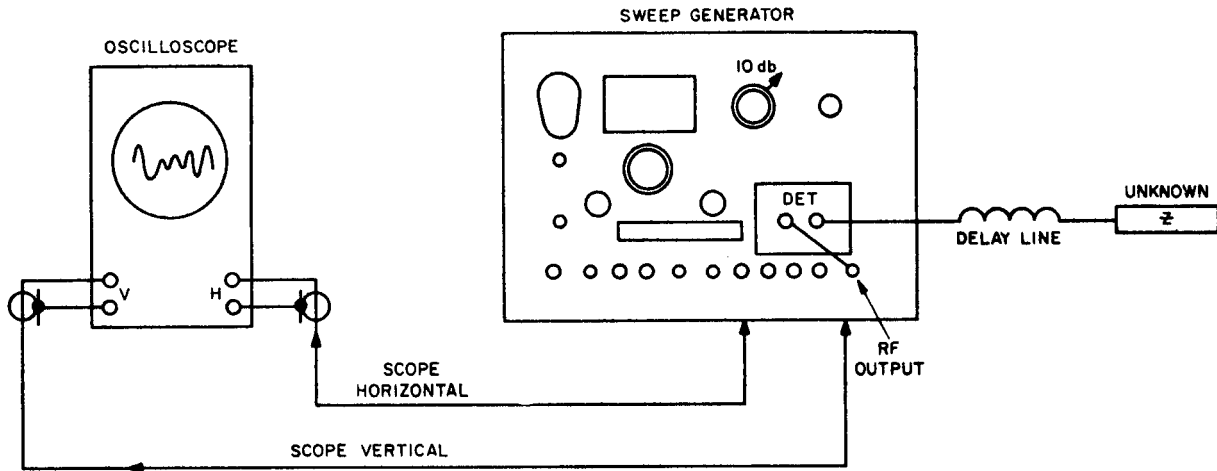

A. CONNECTIONS OF DELAY LINE AND UNKNOWN IMPEDANCE

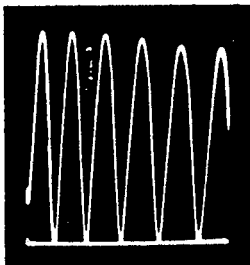

B. RESPONSE CURVE WITH OPEN CIRCUIT AT END OF DELAY LINE.

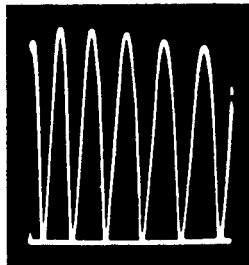

C. RESPONSE CURVE WITH SHORT CIRCUIT AT END OF DELAY LINE.

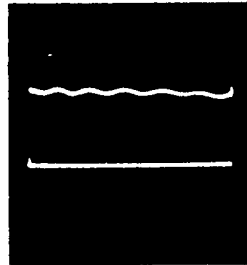

D. RESPONSE CURVE WITH BROADBAND TERMINATION.

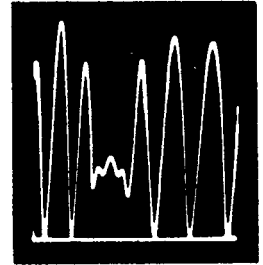

E. RESPONSE CURVE WITH A TERMINATION MATCHING ONLY A NARROW SECTION OF THE SWEEP BAND.

Figure 3-11. Setup for measuring transmission line load impedance.

CHAPTER 4

MAINTENANCE INSTRUCTIONS

4-1. Scope of Operator's Maintenance

The maintenance duties assigned to the operator and organizational repairman of Generator, Signal Sweep AN/USM-203 are listed below together with a reference to the paragraphs covering the specific maintenance functions. The tools and test equipment are listed in appendix C.

- a. Daily preventive maintenance checks and services (para 4-4).
- b. Weekly preventive maintenance checks and services (para 4-5).
- c. Monthly preventive maintenance checks and services (para 4-7).
- d. Quarterly preventive maintenance checks and services (para 4-9).
- e. Cleaning (para 4-10).
- f. Touchup painting (para 4-11).
- g. Visual inspection (para 4-12).
- h. Troubleshooting (para 4-14).
- i. Tube testing (para 4-16).
- j. Repairs and adjustment (para 4-16).

4-2. Preventive Maintenance

Preventive maintenance is the systematic care, servicing, and inspection of equipment to prevent the occurrence of trouble, to reduce downtime, and to assure that the equipment is serviceable.

- a. *Systematic Care.* The procedures given in paragraphs 4-3 through 4-9 cover routine systematic care and cleaning essential in proper upkeep and operation of the equipment.
- b. *Preventive Maintenance Checks and Services.* The preventive maintenance checks and

services charts (para 4-4, 4-5, 4-7, and 4-9) outline functions to be performed at specific intervals. These checks and services are to maintain Army electronic equipment in a combat-serviceable condition; that is, in good general (physical) condition and in good operating condition. To assist operators in maintaining combat serviceability, the charts indicate what to check, how to check, and the normal conditions. If a defect cannot be remedied by the operator, higher category maintenance or repair is required. Records and reports of these checks and services must be made in accordance with the requirements set forth in TM 38-750.

4-3. Preventive Maintenance Checks and Services Periods

Preventive maintenance checks and services of Generator, Signal Sweep AN/USM-203 are required daily, weekly, monthly, and quarterly.

a. Paragraph 4-4 specifies checks and services that must be accomplished daily and under the special conditions listed below.

- (1) When the equipment is initially installed.
- (2) When the equipment is reinstalled after removal for any reason.
- (3) At least once each week if the equipment is maintained in standby condition.

b. Paragraphs 4-5, 4-6, and 4-8 specify additional checks and services that must be performed on a weekly, monthly, and quarterly basis, respectively.

4-4. Daily Preventive Maintenance Checks and Services Chart

Sequence No.	Item to be Inspected	Procedure	References
1 ---	Completeness -----	Check to see that the equipment is complete	--- App B.
2 ---	Exterior surfaces -----	Clean the exterior surfaces, including the panel meter glass and FREQUENCY MEGACYCLES dial. Check meter glass and FREQUENCY MEGACYCLES dial for cracks.	

Sequence No.	Item to be inspected	Procedure	References
3----	Connectors -----	Check the tightness of all connectors.	
4-----	Controls and indicators -----	While making the operating checks, observe that the mechanical action of each knob, dial, and switch is smooth and free of external or internal binding, and no excessive looseness exists. Also, check the meter for sticking or bent pointers.	
5 ----	Preliminary -----	<p><i>a.</i> Set the controls as follows:</p> <ul style="list-style-type: none"> (1) POWER switch to OFF. (2) PREAMPLIFIER controls: <ul style="list-style-type: none"> AC-DC switch: DC. BALANCE control: midrange. GAIN control: fully ccw. (3) BAND SELECTOR switch: UHF. (4) SWEEP WIDTH switch: WIDE. (5) SWEEP WIDTH control: fully cw. (6) RF OUTPUT control: fully cw. (7) ATTENUATOR db switch: 20. <p><i>b.</i> Insert shorting plug into EXT WOBB DRIVE socket on rear panel of main chassis.</p> <p><i>c.</i> Connect only the horizontal input to the oscilloscope.</p>	
6----	POWER switch -----	Set the POWER switch to ON, and turn on oscilloscope. Allow a 30-minute warmup period.	
7-----	PREAMPLIFIER DC LEVEL and BALANCE controls.	<p><i>a.</i> Set oscilloscope vertical sensitivity to 0.1 volt per centimeter and horizontal sensitivity to 2 volts/cm. Center trace on screen.</p> <p><i>b.</i> Connect the SCOPE VERT jack to the dc-coupled vertical input of the oscilloscope. If the trace disappears, return it to the reference line by adjusting the PREAMPLIFIER DC LEVEL control.</p> <p><i>c.</i> Turn the PREAMPLIFIER GAIN control fully clockwise. If the trace moves, return it to the reference line by adjusting the coarse preamplifier balance potentiometer (screwdriver adjustment accessible through the center of the PREAMPLIFIER BALANCE control knob).</p> <p><i>d.</i> Return the PREAMPLIFIER GAIN control fully counterclockwise. If the trace moves, return it to the reference by adjusting the PREAMPLIFIER DC LEVEL control.</p> <p><i>e.</i> Repeat the instructions in <i>c</i> and <i>d</i> above until the PREAMPLIFIER GAIN control can be rotated throughout its entire range without changing the position of the trace by more than 2 cm. Use the front panel PREAMPLIFIER BALANCE (fine) control for finer adjustment.</p> <p><i>f.</i> Remove the connection to the oscilloscope vertical input. If the trace moves, adjust the PREAMPLIFIER DC LEVEL control until the trace remains in position whether or not the vertical input connection is made.</p>	
8----	Uhf SWEEP WIDTH range check.	<p><i>a.</i> Reconnect the oscilloscope vertical input</p> <p><i>b.</i> Use the 1-, 10-, and 100-MHz markers, and check the range of the SWEEP WIDTH control. It should be at least from 500 kHz to 40 percent of center frequency.</p>	

Sequence No.	Item to be inspected	Procedure	References
		<p>c. If the 1-MHz markers are not visible or if they are off frequency, adjust the 1-MHz potentiometer on the harmonic marker chassis, so that none 1-MHz markers appear between any pair of 10-MHz markers.</p> <p>d. Set the SWEEP WIDTH switch to NARROW and check the range of the SWEEP WIDTH control; use the 1-MHz markers. The range should be from 10 kHz to 1 MHz.</p>	
9----	Uhf output level check ----	<p>a. Zero the VOLTS meter with the PULL TURN FOR ZERO control.</p> <p>b. Set PHASING TURN-BLANKING PULL switch to OFF.</p> <p>c. Turn the RF OUTPUT control ccw until the response curve on the oscilloscope just begins to flatten.</p> <p>d. Check to see that the reading on the UHF scale of the VOLTS meter is 0.5 volt rms or more.</p>	
10---	Vhf SWEED WIDTH range check.	<p>a. Set the BAND SELECTOR switch to VHF and the ATTENUATOR db switch to 0.</p> <p>b. Set the SWEEP WIDTH control for maximum sweep width and adjust phasing.</p> <p>c. Set the RF OUTPUT control fully clockwise; then slowly turn it counterclockwise until the response trace flattens.</p> <p>d. Check the range of the SWEEP WIDTH control. It should be from 10 kHz to 1 MHz.</p> <p>e. Pull the 100 MHz MARKER GAIN switch.</p> <p>f. Tune the sweep generator to 0 MHz and adjust the FIXED OSC FREQ control so that the 100-MHz marker is just off the center of the zero beat.</p> <p>g. Set the SWEEP WIDTH switch to WIDE and adjust the SWEEP WIDTH control for maximum sweep width.</p> <p>h. Tune the sweep generator to position the zero beat at the extreme left of the display.</p> <p>i. Set the RF OUTPUT control fully clockwise, then slowly turn it counterclockwise until the trace flattens.</p> <p>j. Use the 100-MHz markers, and verify that the sweep width is at least 400 MHz.</p>	
11----	Vhf output level check ----	<p>a. Zero the VOLTS meter with the PULL TURN FOR ZERO control.</p> <p>b. Set PHASING TURN-BLANKING PULL switch to OFF.</p> <p>c. Turn RF OUTPUT control ccw until the response curve on the oscilloscope just begins to flatten.</p> <p>d. Check to see that the reading on the VHF scale of the VOLTS meter is 0.25 volt rms or more.</p>	

4-5. Weekly Preventive Maintenance Checks and Services Chart

Sequence No.	Item to be inspected	Procedure
1 ----	Power cord -----	Inspect the power cord for chafed, cracked, or frayed insulation. Replace connectors that are broken, arced, stripped, or worn excessively.
2 -----	Handles -----	Inspect handles for looseness. Replace or tighten as necessary.

4-6. Monthly Maintenance

Perform the maintenance functions indicated in the monthly preventive maintenance checks and services chart (para 4-7) once each month. Periodic daily (para 4-4) and weekly (para 4-5) services constitute a part of the monthly checks. A month is defined as approximately 30 calendar days of 8-hour-per-day operation. If the equipment is operated 16 hours a day, the month-

ly preventive maintenance checks and services should be performed at 15-day intervals. Adjustment of the maintenance interval must be made to compensate for any unusual operating conditions. Equipment maintained in a standby (ready for immediate operation) condition must have monthly preventive maintenance checks and services performed on it. Equipment in limited storage (requires service before operation) does not require monthly preventive maintenance.

4-7. Monthly Preventive Maintenance Checks and Services Chart

Sequence No.	Item to be inspected	Procedure
1----	Pluckout items-----	Inspect seating of pluckout items. Make certain that tube clamps grip tube basis tightly. (fig. 2-1).
2----	Terminal blocks-----	Inspect terminal blocks for loose connections and cracked or broken insulation.
3---	Resistors and capacitors.	Inspect the resistors and capacitors for cracks, blistering or other defects.
4----	Insulators-----	Inspect insulators, bushings, and sleeves for cracks, chippings, and excessive wear.
5----	Interior-----	Clean interior of chassis and cabinet.

4-8. Quarterly Maintenance

Quarterly preventive maintenance checks and services on Generator, Sweep Signal AN/USM-203 are required. Periodic daily, weekly, and monthly services constitute a part of the quarterly preventive maintenance checks and services and must be performed concurrently. All deficiencies or shortcomings will be recorded in accordance with the requirements of TM 38-750. Perform all the checks and services listed in the

quarterly preventive maintenance checks and services chart (para 4-9) in the sequence listed. Adjustment of the maintenance interval must be made to compensate for any unusual operating conditions. Equipment maintained in a standby (ready for immediate operation) condition must have quarterly preventive maintenance checks and services performed on it. Equipment in limited storage (requires service before operation) does not require quarterly preventive maintenance.

4-9. Quarterly Preventive Maintenance Checks and Services Chart

Sequence No.	Item to be inspected	Procedure	References
1----	Publications -----	Check to see that all publications are complete, serviceable and current.	DA Pam 310-4.
2----	Modifications -----	Check DA Pam 310-4 to determine if new applicable MWO's have been published. All URGENT MWO's must be applied immediately. All NORMAL MWO's must be scheduled.	TM 38-750 and DA Pam 310-7.
3----	Spare parts -----	Check all spare parts (operator and organizational) for general conditions and method of storage. No overstock should be evident and all shortages must be on valid requisition.	App B.

4-10. Cleaning

Inspect the exterior of the sweep generator. The exterior surfaces should be clean and free of dust, dirt, grease, and fungus.

a. Remove dust and loose dirt with a clean, soft cloth.

Warning: Cleaning compound is flammable and its fumes are toxic. Provide adequate ventilation. Do not use near a flame.

b. Remove grease, fungus, and ground-in dirt from the cases; use a cloth dampend (not wet) with Cleaning Compound (Federal stock No. 7930-395-9542).

c. Remove dust or dirt from plugs and jacks with a brush.

Caution: Do not press on meter face (glass) when cleaning; the meter may become damaged.

d. Clean the front panel, meters, and control knobs; use a soft, clean cloth. If necessary, dampen the cloth with water; mild soap may be used for more effective cleaning.

4-11. Touchup Painting Instructions

Remove rust and corrosion from metal surfaces by lightly sanding them with fine sandpaper. Brush two thin coats of paint on the bare metal to protect it from further corrosion. Refer to the applicable cleaning and refinishing practices specified in TB SIG 364.

Caution: Do not use steel wool. Minute particles of steel wool frequently enter the case and cause harmful internal electrical shorting or grounding of circuits.

4-12. Visual Inspection

Before operating the sweep generator, inspect it. Inspection will save repair time and may also

avoid further damage. Inspect the following for obvious defects:

- a. The seating of all tubes in their sockets.
- b. Wiring connections on the terminal boards.
- c. Wiring connections to the switches and meters on the front panel.
- d. Proper turning of the gears on the tuning dial shaft assembly.

4-13. General Troubleshooting Information

Troubleshooting this equipment is based upon the operational checks in the daily preventive maintenance checks and services chart (para 4-4). Proceed through the items until an abnormal condition or result is observed. When an abnormal condition or result is observed, note the trouble and turn to the corresponding trouble in the troubleshooting chart (para 4-14). Perform the checks and corrective actions indicated in the troubleshooting chart. If the corrective measures indicated do not result in correction of the trouble, higher category maintenance is required. Paragraphs 4-15 and 4-16 contain additional information and step-by-step instructions for performing equipment tests and adjustments to be used during the troubleshooting procedures.

4-14. Troubleshooting Chart

Item No.	Trouble symptoms	Probable trouble	Checks and corrective measures
1----	Trace cannot be balanced on oscilloscope screen.	Defective tube or transistor in pre-amplifier and marker amplifier subassembly.	Check tube V501 and transistors Q501 and Q502; replace as necessary.
2----	Dc level shift in oscilloscope screen.	Defective tube in preamplifier and marker amplifier subassembly.	Check tube V502; replace as necessary (para 4-15).
3----	Insufficient sweep width.	a. Insufficient warmup time ----- b. Improper setting of SWEEP WIDTH control. c. Improper adjustment of WOBB DRIVE LIMIT control.	a. Allow at least 30 minutes warmup time. b. Adjust SWEED WIDTH control to proper setting. c. Readjust WOBB DRIVE LIMIT control for proper sweep width.
4----	No output on either uhf or vhf.	a. Defective fuse ----- b. Defective tube in ALC sub-assembly.	a. Check ac line fuse F1, B+ fuse F2, and B- fuse F3; replace as necessary (para 3-16). <i>Note.</i> A defective fuse usually indicates some other trouble. If replaced fuses blow, higher maintenance category repair is required. b. Check tubes V301, V302, V303, and V304; replace as necessary (para 4-15).
5-----	No markers on oscilloscope pattern.	a. Defective 5-MHz crystal ----- b. Defective 5-MHz oscillator stage in harmonic marker generator subassembly.	a. Replace 5-MHz crystal V401. b. Check tube V401; replace as necessary (para 4-15).

Item No.	Trouble symptom	Probable trouble	Checks and corrective measures
6----	No 1-MHz markers appear on oscilloscope pattern.	Defective 5-MHz oscillator stage in harmonic marker generator sub-assembly.	Check tube V401; replace as necessary (para 4-15).
7----	No 10MHz markers appear on oscilloscope pattern.	Defective 5-MHz oscillator or 10-MHz multiplier stage in harmonic marker generator subassembly.	Check tubes V401 and V402; replace as necessary (para 4-15).
8----	No 100-MHz markers appear on oscilloscope pattern.	Defective 10-MHz or 100-MHz multiplier stage in harmonic marker generator subassembly.	Check tube V402 or V403; replace as necessary (para 4-15).

4-15. Tube-Testing Techniques

When trouble occurs, check all wiring and connections before removing any tubes. Try to isolate the trouble to a component or stage. If tube failure is suspected, use the applicable procedure described below to check the tubes.

Caution: Do not rock or rotate a tube when removing it from a socket; pull it straight out with a tube puller.

a. Tube Substitution Method. Replace a suspected tube with a new one. If the equipment still does not work, remove the new tube and put back the original tube. Repeat this procedure with each suspected tube until the defective tube is located.

b. Use of Tube Tester. Remove and test one tube at a time. Discard a tube only if its de-

fect is obvious or if the tube tester shows it to be defective. Do not discard a tube that tests at or near its minimum test limit on the tube tester. Put back the original tube, or insert a new one if required, before testing the next one.

4-16. Fuse Replacement

a. Turn the fuseholder cap counterclockwise and remove it from the fuseholder.

b. Remove the defective fuse from the fuseholder cap.

c. Insert a new fuse in the fuseholder cap.

Note. Be sure the B+ and B- fuses (F2 and F3) are slow-blow types with a rating of 0.1 ampere.

d. Replace the fuseholder cap in the fuseholder and turn it clockwise to tighten.

CHAPTER 5

SHIPMENT, LIMITED STORAGE, AND DEMOLITION TO PREVENT ENEMY USE

Section I. SHIPMENT AND LIMITED STORAGE

5-1. Disassembly of Equipment

Prepare the AN/USM-203 for shipment and storage as follows:

- a. Disconnect all external leads and the power cable.
- b. Install the sweep oscillator shipping screw; reverse the procedure described in paragraph 2-3.

- c. Secure the cabinet top cover by turning the screw-fastener which latches the cover.

5-2. Repacking for Shipment or Limited Storage

To repack the equipment, reverse the unpacking procedure (para 2-2).

Section II. DEMOLITION OF MATERIAL TO PREVENT ENEMY USE

5-3. Authority for Demolition

The demolition procedures given in paragraph 5-4 will be used to prevent the enemy from using or salvaging this equipment. Demolition of the equipment will be accomplished only upon the order of the commander.

5-4. Methods of Destruction

The tactical situation and time available will determine the method to be used when destruction of equipment is ordered. In most cases, it is preferable to demolish completely some portions of the equipment rather than partially destroy all the equipment units.

a. *Smash.* Smash the interior subassemblies of the set.

(1) Smash the connectors, meters, knobs, and dials, the RF section, and the power supply.

(2) Remove the chassis from the cabinet. Smash as many of the exposed parts of the various subassembly as as possible.

b. *Cut.* Cut cabling, cording, and wiring. Cut all cords and cables in a number of places.

Warning: Be extremely careful with explosives and incendiary devices. Use these items only when the need is urgent.

c. *Burn.* Burn the technical manuals first. Burn as much of the equipment as is flammable. Burn the cut cables, internal wiring, and spare parts. Complete the destruction of the unit.

d. *Explode.* Use explosives to complete demolition or to cause maximum damage before burning, when time does not permit complete demolition by other means. Powder charges, fragmentation grenades, or incendiary grenades may be used. Incendiary grenades usually are most effective if destruction of small parts and wiring is desired.

(1) Use a fragmentation grenade to destroy the interior of the AN/USM-203. Open the top cover of the cabinet and drop the grenade into the interior.

(2) For quick destruction of the AN/USM-203 place an incendiary grenade inside the unit. Get away from the unit after the grenade is placed.

c. *Dispose.* Bury or scatter destroyed parts or throw them into nearby waterways. This is particularly important if a number of parts have not been completely destroyed.

APPENDIX A

REFERENCES

Following is a list of references available to the operator and organizational repairman of Sweep Signal Generator AN/USM-203:

DA Pam 310-4	Index of Technical Manuals, Technical Bulletins, Supply Manuals (types 7, 8, and 9), Supply Bulletins, and Lubrication Orders
DA Pam 310-7	U.S. Army Equipment Index of Modification Work Orders.
SB 38-100	Preservation, Packaging, and Packing Materials, Supplies, and Equipment Used by the Army.
TB SIG 361	Field Instruction for Painting and Preserving Electronics Command Equipment.
TM 38-750	Army Equipment Record Procedures.

APPENDIX C

MAINTENANCE ALLOCATION

Section I. INTRODUCTION

C-1. General

This appendix provides a summary of the maintenance operations for AN/USM-203. It authorizes categories of maintenance for specific maintenance functions on repairable items and components and the tools and equipment required to perform each function. This appendix may be used as an aid in planning maintenance operations.

C-2. Maintenance Function

Maintenance functions will be limited to and defined as follows:

a. Inspect. To determine the serviceability of an item by comparing its physical, mechanical, and/or electrical characteristics with established standards through examination.

b. Test. To verify serviceability and to detect incipient failure by measuring the mechanical or electrical characteristics of an item and comparing those characteristics with prescribed standards.

c. Service. Operations required periodically to keep an item in proper operating condition; i.e., to clean (decontaminate), to preserve, to drain, to paint, or to replenish fuel, lubricants, hydraulic fluids, or compressed air supplies.

d. Adjust. To maintain, within prescribed limits, by bringing into proper or exact position, or by setting the operating characteristics to the specified parameters.

e. Align. To adjust specified variable elements of an item to bring about optimum or desired performance.

f. Calibrate. To determine and cause corrections to be made or to be adjusted on instruments or test measuring and diagnostic equipments used in precision measurement. Consists of comparisons of two instruments, one of which is a certified standard of known accuracy, to detect and adjust any discrepancy in the accuracy of the instrument being compared.

g. Install. The act of emplacing, seating, or fixing into position an item, part, module (component or assembly) in a manner to allow the proper functioning of the equipment or system.

h. Replace. The act of substituting a serviceable like type part, subassembly, or module (component or assembly) for an unserviceable counterpart.

i. Repair. The application of maintenance services (inspect, test, service, adjust, align, calibrate, replace) or other maintenance actions (welding,

grinding, riveting, straightening, facing, re-machining, or resurfacing) to restore serviceability to an item by correcting specific damage, fault, malfunction, or failure in a part, subassembly, module (component or assembly), end item, or system.

j. Overhaul. That maintenance effort (service/action) necessary to restore an item to a completely serviceable/operational condition as prescribed by maintenance standards (i.e., DMWR) in appropriate technical publications. Overhaul is normally the highest degree of maintenance performed by the Army. Overhaul does not normally return an item to like new condition.

k. Rebuild. Consists of those services/actions necessary for the restoration of unserviceable equipment to a like new condition in accordance with original manufacturing standards. Rebuild is the highest degree of materiel maintenance applied to Army equipment. The rebuild operation includes the act of returning to zero those age measurements (hours, miles, etc.) considered in classifying Army equipments/components.

C-3. Column Entries

a. Column 1, Group Number. Column 1 lists group numbers, the purpose of which is to identify components, assemblies, subassemblies, and modules with the next higher assembly.

b. Column 2, Component Assembly. Column 2 contains the noun names of components, assemblies, subassemblies, and modules for which maintenance is authorized.

c. Column 3, Maintenance Functions. Column 3 lists the functions to be performed on the item listed in column 2. When items are listed without maintenance functions, it is solely for purpose of having the group numbers in the MAC and RPSTL coincide.

d. Column 4, Maintenance Category. Column 4 specifies, by the listing of a "worktime" figure in the appropriate subcolumn(s), the lowest level of maintenance authorized to perform the function listed in column 3. This figure represents the active time required to perform that maintenance function at the indicated category of maintenance. If the number or complexity of the tasks within the listed maintenance function vary at different maintenance categories, appropriate "worktime" figures will be shown for each category. The number of task-hours specified by the "worktime"

figure represents the average time required to restore an item (assembly, subassembly, component, module, end item or system) to a serviceable condition under typical field operating conditions. This time includes preparation time, troubleshooting time, and quality assurance/quality control time in addition to the time required to perform the specific tasks identified for the maintenance functions authorized in the maintenance allocation chart. Subcolumns of column 4 are as follows:

- C - Operator/Crew
- O - Organizational
- F - Direct Support
- H - General Support
- D - Depot

e. Column 5, Tools and Equipment. Column 5 specifies by code, those common tool sets (not individual tools) and special tools, test, and support equipment required to perform the designated function.

f. Column 6, Remarks. Column 6 contains an alphabetic code which leads to the remark in section IV, Remarks, which is pertinent to the item opposite the particular code.

C-4. Tool and Test Equipment Requirements (sec III)

a. Tool or Test Equipment Code. The numbers in

this column coincide with the numbers used in the tools and equipment column of the MAC. The numbers indicate the applicable tool or test equipment for the maintenance functions.

b. Maintenance Category. The codes in this column indicate the maintenance category allocated the tool or test equipment.

c. Nomenclature. This column lists the noun name and nomenclature of the tools and test equipment required to perform the maintenance functions.

d. National/NATO Stock Number. This column lists the National/NATO stock number of the specific tool or test equipment.

e. Tool Number. This column lists the manufacturer's part number of the tool followed by the Federal Supply Code for manufacturers (5-digit) in parentheses.

C-5. Remarks (sec IV)

a. Reference Code. This code refers to the appropriate item in section II, column 6.

b. Remarks. This column provides the required explanatory information necessary to clarify items appearing in section II.

(Next printed page is C-3.)

SECTION II MAINTENANCE ALLOCATION CHART
FOR
GENERATOR, SIGNAL SWEEP - AN/USM-203

(1) GROUP NUMBER	(2) COMPONENT/ASSEMBLY	(3) MAINTENANCE FUNCTION	(4) MAINTENANCE CATEGORY					(5) TOOLS AND EQPT.	(6) REMARKS
			C	O	F	H	D		
00	Generator, Signal Sweep	Inspect		0.2				Visual Only Simple Opera- tional checks Only. 1 thru 20 1 thru 7 20 Replace fuses, knobs, etc. 19 1 thru 7 19	
		Test		0.2					
		Test Test Service				0.7	1.5		
		Repair		0.2 0.2					
01	Generator, Signal Sweep, SG-593/U	Test				0.7		1 thru 7 19	
		Repair Rebuild				0.6	2.0		
0101	Main Chassis and Panel Assy	Test				0.4		1 thru 7 19	
		Repair Rebuild				0.5	2.0		
0102	AIC Chassis	Replace					1.5	1 thru 7 19	
		Rebuild					1.5		
0103	Marker Chassis	Replace						19	
		Rebuild					1.5		
0104	Presamp Chassis	Replace						19	
		Rebuild					1.5		
0105	Mixer and VHF-AIC Chassis	Replace						19	
		Rebuild					1.5		
0106	Sweep Head *								
02	Adapter	Replace					0.2		
	* Unrepairable: Entire Set May be unserviceable if this unit is defective or out of adjustment.								

SECTION III TOOL AND TEST EQUIPMENT REQUIREMENTS
FOR
 GENERATOR , SIGNAL SWEEP - AN/USM-203

TOOL OR TEST EQUIPMENT REF CODE	MAINTENANCE CATEGORY	NOMENCLATURE	NATIONAL/NATO STOCK NUMBER	TOOL NUMBER
		AN/USM-203 (continued)		
1	H,D	ATTENUATOR CN-764/U	85-00-020-2990	
2	H,D	COMPARATOR, FREQUENCY, ELECTRONIC CM-77/USM	25-00-080-7204	
3	H,D	COUNTER, ELECTRONIC, DIGITAL READOUT AN/USM-207	25-00-044-3228	
4	H,D	MULTIMETER ME-260/U	25-00-913-9781	
5	H,D	OSCILLOSCOPE AN/USM-281	25-00-228-2201	
6	H,D	TEST, SET, OSCILLATOR AN/PRM-10	25-00-339-2046	
7	H,D	WATTMETER AN/URM-98	25-00-566-4990	
8	D	SIGNAL GENERATOR SG-71/FCC or equal	25-00-669-0255	
9	D	VHF MARKER GENERATOR, RCA WR99A, or equal		
10	D	UHF MARKER GENERATOR, GENERAL RADIO 1209C, or equal		
11	D	PRECISION ATTENUATOR, JERROLD ATV-109, or equal		
12	D	FIXED ATTENUATOR, 1 db, JERROLD FA-1, or equal		
13	D	FIXED ATTENUATOR, 3 db, JERROLD FA-3, or equal		
14	D	COAXIAL COMPARATOR, JERROLD TC-2, or equal		
15	D	FILTER , CUTOFF , 16MHz*		
16	D	FILTER , BANDPASS , 15MHz*		
17	D	RF FIELD STRENGTH METER, JERROLD 727, or equal		
18	D	MATCHING PAD, JERROLD MLP 50/75F, or equal		
19	H,D	TOOL KIT TK-100/G	180-00-605-0079	
20	O	TOOLS AND TEST EQUIPMENT AVAILABLE TO THE ORGANIZATIONAL REPAIRMAN BECAUSE OF HIS ASSIGNED MISSION.		

By Order of the Secretary of the Army:

W. C. WESTMORELAND,
*General, United States Army,
 Chief of Staff.*

Official:

KENNETH G. WICKHAM,
*Major General, United States Army,
 The Adjutant General.*

Distribution:

Active Army:

USASA (2)
 CNGB (1)
 ACSC-E (2)
 Dir of Trans (1)
 CofEngrs (1)
 TSG (1)
 CofSptS (1)
 USAARENBD (2)
 USACDC Agcy (1)
 USAMC (5)
 USCONARC (5)
 ARADCOM (5)
 ARADCOM Rgn (2)
 OS Maj Comd (4)
 LOGCOMD (2)
 USAMICOM (4)
 USASTRATCOM (4)
 USATECOM (2)
 USAESC (70)
 MDW (1)
 Armies (2)
 Corps (2)
 Svc Colleges (2)
 USASCS (40)
 USAADS (60)
 USAAMS (2)
 USAARMS (2)
 USAIS (2)
 USAES (2)
 USATC Armor (2)
 USATC Inf (2)
 USASTC (2)
 WRAMC (1)
 Army Pic Cen (2)
 USACDCEC (10)
 Instl (2) except
 Fort Gordon (10)

Fort Huachuca (10)
 Fort Carson (25)
 Fort Knox (12)
 WSMR (5)
 Army Dep (2) except
 LBAD (14)
 SAAD (30)
 TOAD (14)
 LEAD (7)
 SHAD (3)
 NAAD (5)
 SVAD (5)
 CHAD (3)
 ATAD (10)
 GENDEPS (2)
 Sig Sec Gen Deps (5)
 Sig Dep (12)
 Sig FLDMS (2)
 USAERDAA (2)
 USAERDAW (13)
 USACRREL (2)
 MAAG (2)
 USARMIES (2)
 Units org under fol TOE:
 (2 copies each)
 11-57
 11-97
 11-98
 11-117
 11-127
 11-155
 11-157
 11-158
 11-500 (AA-AC)
 11-587
 11-592
 11-597

NG: None.

USAR: None.

For explanation of abbreviations used, see AR 320-50.

